



The Analysis and Optimization of Business Processes for Students in Higher Education Based on Togaf 9.2

M.Khairul Anam^{1*}, Torkis Nasution², Susi Erlinda³, Lusiana Efrizoni⁴, Susanti⁵

¹Information Technology Department, STMIK Amik Riau, Indonesia

^{2,3,4,5}Informatics Engineering Department, STMIK Amik Riau, Indonesia

Abstract.

Purpose: The IT Blueprint is used as a guideline in achieving organizational goals, such as the built and development of information technology (IT) infrastructure. STMIK Amik Riau is one of the universities vision to become an excellent university in Sumatra by 2030. To achieve this vision, it is necessary to develop various units, one of which is the built and development of IT in student services. To build IT for student services, an enterprise architecture is needed so that the development is more focused.

Study design: In this study, TOGAF became the framework used to design, plan, implement, and manage the company's organizational architecture. TOGAF has 8 phases, but this research takes 6 phases: Architecture Vision, Business Architecture, Information System Architectures, Technology Architecture, Opportunities and Solutions, and Migration Planning.

Result: The results obtained in this study are the creation of IT blueprints for student business processes. There are several updates in each process, especially in the information system architecture, then in business processes and technology. There are also updates that need to be done. This study also provides several reasons for updating the Opportunity and Solutions. Other than that, this research guides to apply the updates based on priorities that must be applied to migration planning.

Novelty: In the information system architecture, 18 applications become service systems for students. After analyzing it into 31 applications, they will later be used to support good services for students.

Keywords: Higher Education, Enterprise Architecture, Togaf 9.2, Blueprint

Received April 2021 / **Revised** May 2021 / **Accepted** November 2021

This work is licensed under a [Creative Commons Attribution 4.0 International License](https://creativecommons.org/licenses/by/4.0/).



INTRODUCTION

One of the efforts to increase the function and role of an organization is undertaken through information technology. Information technology is widely used in almost all fields, including education, business, social, and so on. The fourth industrial revolution or industry 4.0 is the entrance to the digitalization era, which refers to an overview of the situation of changing lifestyles and behavior of individuals and organizations currently [1]. Higher Education is a scientific institution tasked with providing education and teaching above secondary level universities based on the Indonesian national culture [2]. Advances in information technology at universities promise ease in the development of information services, especially for institutions in electronic information management [3][4]. For this reason, it is necessary to periodically improve information technology so that it can run as expected. STMIK Amik Riau is a higher education organization in the field of education, especially information technology.

STMIK Amik Riau is currently attempting to build an integrated information system from one system to another. An integrated information system is a system that enables sharing of data for the entire organization. An integrated system is also called an ERP (Enterprise Resource Planning) system because all operational data is located in a central database and can be accessed by users in an organization [5]. STMIK Amik Riau has the vision to become a superior university in Sumatra by 2030. One of the efforts to achieve this vision is to conduct improvements in the business process sector of students. Several researchers have improved university business processes, including [6], who created an IT blueprint for integrating information systems at STT Garut so that business processes at the university can run smoothly

*Corresponding author

Email Author: khairulanam@sar.ac.id (Anam), torkisnasution@stmik-amik-riau.ac.id (Nasution), susierlinda@stmik-amik-riau.ac.id (Erlinda), lusiana@sar.ac.id (Efrizoni), susanti@sar.ac.id (Susanti)

Doi: [10.15294/sji.v8i1.29952](https://doi.org/10.15294/sji.v8i1.29952)

and efficiently. Another study [7] made improvements to higher education business processes that were still running separately in each field. The business process, in this case, was designed using an enterprise architecture with the TOGAF framework.

In the current business sector of student at STMIK Amik Riau started from forming an admissions decree until the goal of increasing the rank of national and international universities. For achieving this goal, it is necessary to improve the sectors that must be improved because it involves many units in student business processes. The steps in this business process start from the formation of a decree for admission of new students, conducting promotions, registering prospective students, conducting entrance tests, announcing graduation, becoming students, participating in the teaching and learning process, receiving the thesis title, thesis proposal examination, thesis examination, graduated, become alumni, filling tracer, and rank of campus.

However, in the existing steps in the business, there are several obstacles, such as the delay in processing or receiving data from certain units, which lead to the leadership being slow in making decisions. In addition, it is difficult to maintain communication with alumni because there is no platform or media that can ensure communication between the campus and alumni is maintained.

To overcome this problem, one of the ways is to implement enterprise architecture. Enterprise Architecture (EA) has developed into a subject, operating with models at the level of organizations, groups of companies and countries [8]. Implementing EA aims to create alignment between business and IT for organizational needs [9]. To design an EA, a framework is needed. There are several frameworks used to build an EA, including the Federal Enterprise Architecture Framework (FEAF), Zachman Framework, Treasury Enterprise Architecture Framework (TEAF), DoD Architecture Framework (DoDAF), The Open Group Architectural Framework (TOGAF), and others. In this research, the framework used was TOGAF. TOGAF has several versions. This research used TOGAF 9.2 to design and develop EA. TOGAF 9.2 has been used due to its detailed and complete tools, this is different from other EA frameworks [10][11]. Previous studies that have used the TOGAF framework to design EA include [12] designing a framework that can assist the government in implementing cloud technology in accordance with ROCCA and TOGAF 9.2 in SKK Migas. Research [13] conducted information technology governance design using TOGAF [14]. Further, other researchers [15] designed an enterprise architecture in universities.

This research conducted begins with analyzing the condition of the existing information system at STMIK Amik Riau and measuring the maturity level of the system that has been applied the existed business process at STMIK Amik Riau, especially in the students' business process. After discovering the measurement results and an overview of the system, the next step is to design an AE based TOGAF 9.2 on the problems of each work unit at STMIK Amik Riau. The goal is to produce an IT blueprint that used by the campus as a reference for improving ongoing business processes.

METHODS

This research used togaf 9.2 framework, to make it easier to conduct research and apply this method, Figure 1 is the research flow in this research.

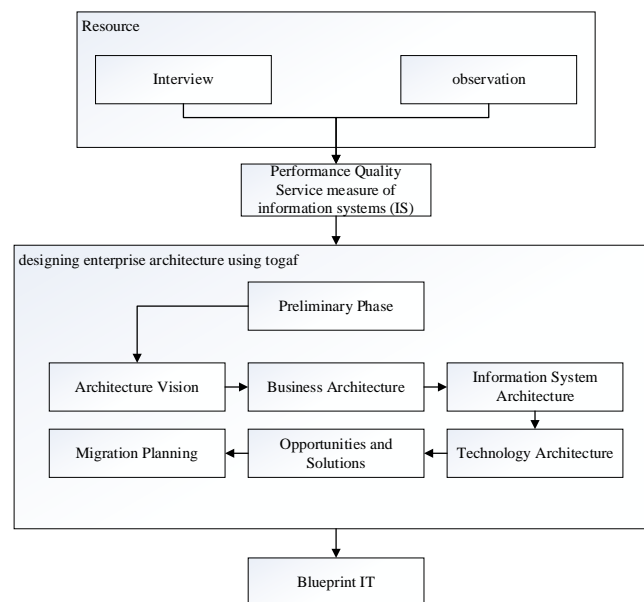

Figure 1. Research flow

The following is an explanation of the research flow:

Resource

The activity in this stage was looking for previous studies related to the research that was carried out, such as national and international journals, websites, and books. As well as conducting interview with rector, vice-rector for academic studies, vice-rector for students, vice-rector for administration and finance, academic department, BAAK, Finance, and lecturers. Also, survey of the current system, business process, data, and technology related to the object of research, namely STMIK Amik Riau.

The measurement of service quality

The measurement of the system is an essential thing to be undertaken to discover the level of maturity of the system implemented in higher education. In measuring this research used the framework of the Information Technology Infrastructure Library (ITIL) v3 and the Capability Maturity Model Integration (CMMI). This measurement was carried out because the object of research, namely STMIK Amik Riau, has implemented several systems in the student business area starting from registration until students become alumni.

According to Mourad EL Baz [16], ITIL (Information Technology Infrastructure Library) is a policy concept regarding information technology management so that this technology can be integrated with the company's business processes. Whereas, the CMMI model is a process improvement approach that provides organizations with the essential elements of an effective process that ultimately improves performance [17]. This study used ITIL v3 due to this framework had a domain based on service, namely service operation, then CMMI was used to measure the maturity level of the system.

Designing Architecture Enterprise Using TOGAF 9.2

Enterprise architecture (EA) is the definition and representation of a high-level view of an enterprise's business processes and IT systems, their interrelationships, and the extent to which these processes and systems are shared by different parts of the enterprise [18]. The domain of enterprise architecture does not merely affect internal resources such as IT elements, processes and personnel, but also organizational external relations[19]. EA has 4 aspects, Figure 2 is an overall and thorough aspect[20].

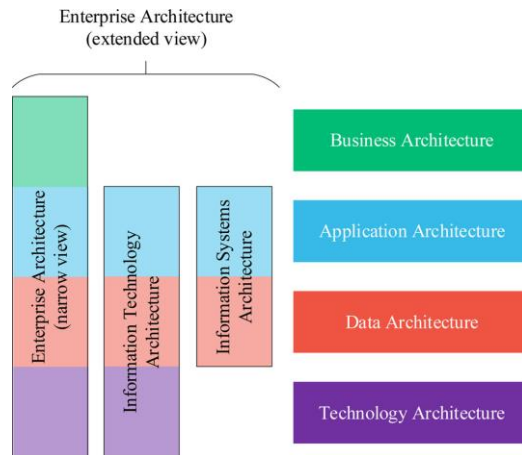

Figure 2. EA definition, narrow and extended views [20].

This study conducted EA design by looking at the existing EA conditions in a company or organization through 4 aspects, namely business, applications, data, and technology. Then, after obtaining the results of the observations, the effectiveness of the systems used by the company / organization was measured. The results of this measurement are one of the bases for designing EA. One of the frameworks used to build enterprise architecture is TOGAF.

Togaf is a collection of methods, techniques, and best practices in developing Enterprise Architecture managed by The Open Group [21]. Togaf 9.2 is the same as other togaf but there are some differences, namely in the introduction which is called as TOGAF Library[22]. Following is the framework togaf 9.2 as shown in Figure 3 [12].



Figure 3. TOGAF 9.2 Phases and Artifacts [12]

The following are some studies that the use togaf as a framework used to develop or design EA in higher education [23], [7], [24], [25], [26], and [6].

This stage is to design an AE based on togaf 9.2. In togaf 9.2, it has 8 stages starting from Architecture vision to Architecture Change Management. This research was conducted using 6 stages, it is due to the research was carried out to design an IT blueprint as a reference for the STMIK Amik Riau campus in developing business processes on the student aspect.

Preliminary Phase

The preliminary phase determines the framework and scope of the Enterprise Architecture (EA) to be developed, including the definition of management elements where the architectural team and organization will also be formed at this stage [27].

Architecture Vision

Architecture Vision is the initial phase in TOGAF ADM which aims to align views on the reasons for designing enterprise architecture in achieving the organization's main goals and defining the scope of architectural planning to be built on the object of research. In addition, the architecture vision is used to define stakeholders and their roles, business goals, triggers for the organization's business strategy, and the architectural vision of the organization. At the architecture vision stage, it will produce several artifacts, one of which is a value chain diagram. This artifact is used to describe the grouping of activities based on primary activity and support activity in carrying out organizational operational activities that can create value and competitive advantage for the organization [28].

Business Architecture

The business architecture stage will determine the desired business model or business activity based on the organization's business scenario. There are 3 things that must be done in this stage, namely: Determine the point of view to show how stakeholders are related to each other, determine relevant resources such as models and patterns used, then select and define common tools and methods for modeling, such as the Unified Modeling Language (UML) and Function Hierarchy Charts that can be used to build the required model [27].

Information System Architecture

The information system architecture stage determines the data architecture and application architecture. Data architecture focuses more on how data is used for the needs of business functions, processes and services. Tools that can be used in this stage include Activity Diagrams and Class Diagrams. The stages in creating a data architecture are defining entities and creating a conceptual model of entity relationships. The application architecture in this stage places more emphasis on how application requirements are planned. This is done by defining the application stage and creating a conceptual business process model based on the business scenario activities of the application [29].

Technology Architecture

The technology architecture stage defines the main technologies needed to provide a technological support environment for applications and data that will be managed using these technologies. The steps needed to build a technology architecture are to identify the principles of technology and platforms, define the technology platform and distribution, relate the technology platform to applications and business functions, and distribute the technology architecture [30].

Migration Planning

Migration planning is a migration process that is carried out by ensuring the implementation plan. Coordination of migration with organizations in this case also needs to be carried out with the aim of managing and implementing changes to the organization's portfolio as a whole. The migration planning stage will produce several artifacts including implementation factor assessment and deduction matrix and architecture roadmap [28].

Opportunities and solution

Opportunities and solutions is a TOGAF phase that functions as an evaluation of the architectural design model created [31].

Analysis Results (Blueprint)

This stage is the result of the research conducted. The results of this research will be used a reference later for developing existing businesses on the STMIK Amik Riau campus. STMIK Amik Riau does not have an IT blueprint but the information system used to serve students is quite complete. The absence of an IT blueprint causes several obstacles that often occur, such as the length of time getting freshmen data, and reporting data to PDPT.

RESULT AND DISCUSSION

The first stage in this research is to review the business process and find out the obstacles that are often found on the STMIK Amik campus in Riau. This process will then be used to measure the maturity level of each system in each business process. Measurement of maturity level can be done through several frameworks, including Cobit [32][33], CMII [34][35], SAMM Lufman [36], ITIL [37][38]. This research uses the ITIL framework. The reason is because the framework will later be combined with Togaf as has been done by several researchers [39][40]. According to harani [39] it is explained that these two methods focus on the integration of IT services and business processes. [41] stated that users should be able to adopt and adapt both methods according to the needs and environment of the organization. Therefore, these two methods can be run together to improve business processes in the organization.

The first step in this research is to measure using a questionnaire that refers to the ITIL V3 framework, especially in the service operation domain. ITIL is a best practice of IT Service Management which is the most popular choice today as a business analyst framework for a client/client for defining a consistent and comprehensive business roadmap and IT infrastructure. It aims to make the company's business (business plan/strategy) in line with IT and infrastructure. In addition, it is hoped that through this method can achieve the quality of managed IT service support (IT Service Management Forum) [42].

The level of the existing system at STMIK Amik Riau Is known by providing questionnaires to stakeholders. The questionnaire is related to system managers and users of the existing system at STMIK Amik Riau using the RACI Model. This questionnaire is used to collect data that has an index value of each of the measurement criteria carried out. To measure the index value, the formula used in this study is the formula of equation 1 as follows.

$$Index = \frac{\Sigma(\text{Total of answers})}{\Sigma(\text{Question of Questionnaire})} \quad (1)$$

Dealing with the results of the above equation, the results are as in table 1.

Table 1. Index of Maturity Level

Subdomain	Value	Level	Desc
Event Management	1.50	1	Initial
Incident Management	1.52	1	Initial
Request Management	1.78	2	Repeatable
Problem Management	1.22	1	Initial
Access Management	2.88	2	Repeatable
AVG Maturity Level	1.78	2	Repeatable

Table 1 shows that the service information system for students indicates that the current maturity level is still at level 2 or what is called Repeatable. Repeatable explains that the current student service information system already has a level of discipline and compliance with applicable regulations and operational standards[43].

The increase of this level is necessary due to the leadership of STMIK Amik Riau has willingness of STMIK Amik Riau to be at level 3 or defined. One of the efforts made to improve the system was through AE. The following is the AE process in this study which refers to the framework togaf 9.2 [44]:

Preliminary

This phase describes the preparation and initiation activities required to meet the business direction for the new enterprise architecture, including the definition of organizational architecture and definition of principles. In this research, for the preliminary purposes of collecting analytical data, namely the business process of STMIK Amik Riau, especially for students. Figure 4 is a business process that exists on the campus

To achieve the vision of STMIK Amik Riau, it is necessary to renew existing business processes. Updates are undertaken to make repairs that have become an obstacle to the ongoing process. By the updating of each process, it is hoped that the problems that often occur can run well.

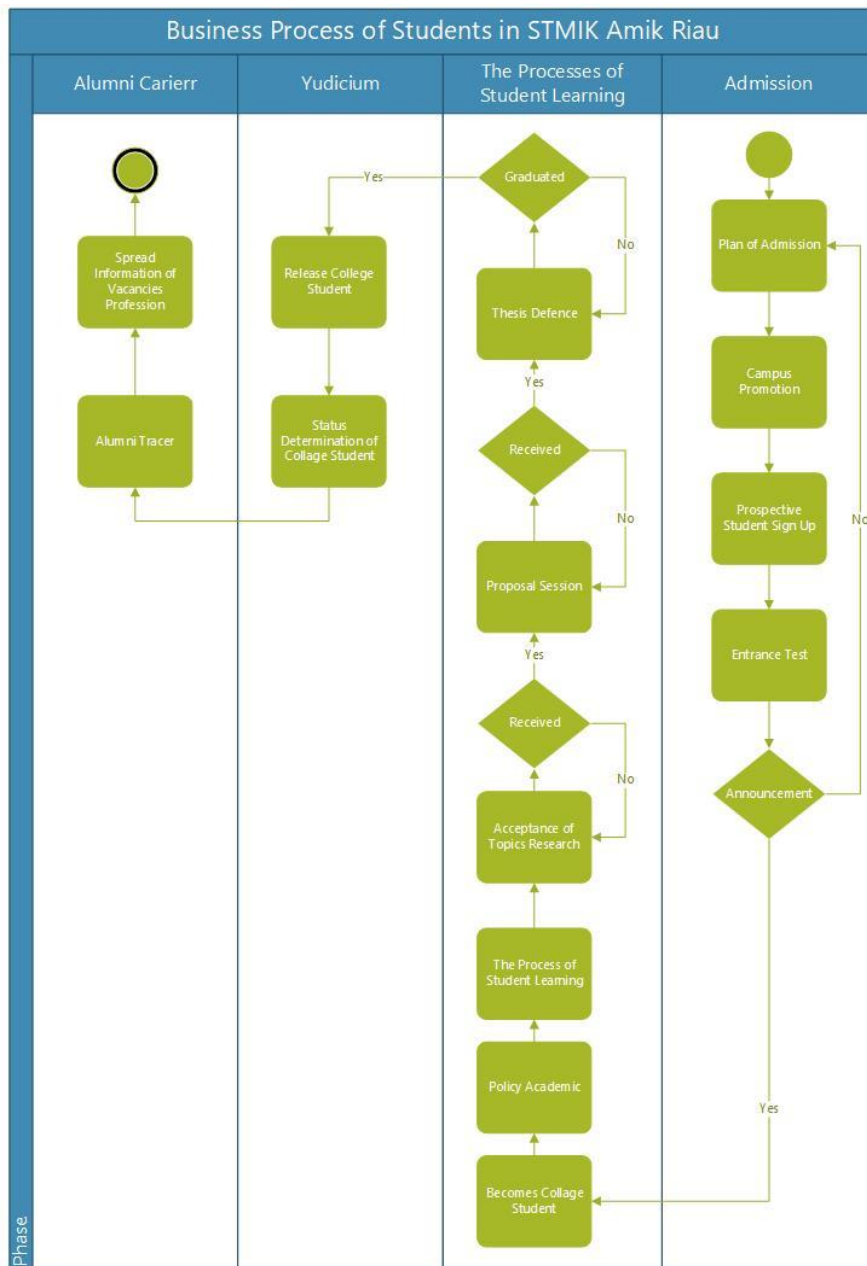

Figure 4. Business Process of STMIK Amik Riau

Architecture Vision

This phase reveals that the initial phase of an architectural development method (ADM). This phase includes information about identifying the scope, stakeholders, creating an architectural vision and obtaining approval. To build an Architecture Vision in this study, we see the vision that owned by STMIK Amik Riau, which is to become a university in Sumatra by 2030. One of the efforts to achieve this vision is to increase the rank of campuses at both National and International.

To simplify this process, the main and supporting activities will be divided. To separate these activities, this research used a value chain. Value Chain analysis is used to identify the main activities and support activities that are carried out internally in higher education [45][46]. In accordance with the duties and functions of the organizational structure, it can be described the Value Chain activities in STMIK Amik Riau in Figure 5.

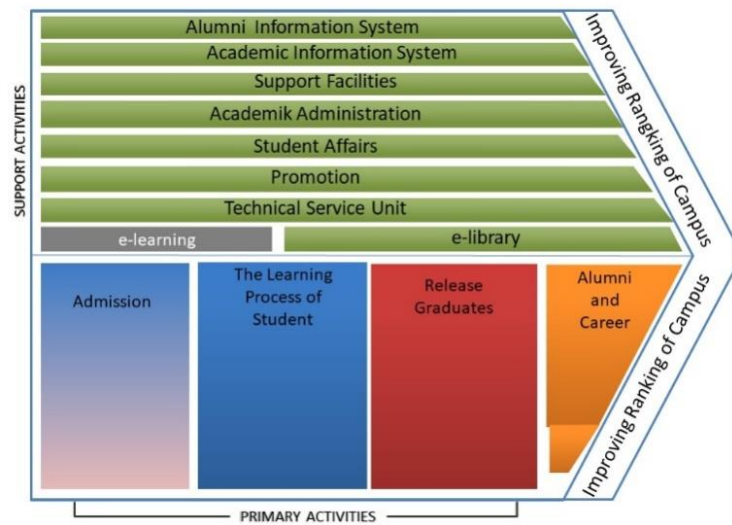

Figure 5. Value chain of STMIK Amik Riau

Business Architecture

This phase describes the development of a business architecture to support the agreed upon vision of this research architecture and refers to vision of Amik Riau and STMIK. Based on the business process and value chain, Vision architecture will describe in more detail each process and add some new processes from the ones that are already running if it is needed to produce better business processes.

The Business Process of Admissions of Freshmen (CAMABA)

The business process focuses on managing the admission of freshmen from meetings or planning for new admissions, campus promotions, registering camaba, entrance tests, graduation announcements, to be a student. The following is a grouping of existing activities and updates that have been added, as shown in table 2. The blue items mean the business processes will be developed, whereas the STMIK Amik Riau campus has carried out the black items.

Table 2. The business processes of PMB

No	Name of Sub Process	Detail Activity
1.1	planning for new student admission	- Determining PMB Team - Budgeting
1.2	campus promotion	- Time Schedule of PMB - Market research - Promotion strategy - Monitoring and strategy evaluation - Promotion - Promotion report
1.3	prospective new students register	- Online or offline registration - Completing the registration documents
1.4	selection or entrance test	- Determining the entrance selection system - Determining the material of entrance selection
1.5	test result announcement	- Entrance selection - Selection result management - Selection result announcement
1.6	becoming college student	- Entrance selection report - Collecting students registration - Determining student's ID - Printing the Student ID Card - Introducing the campus life to new students (PKKMB) - Report of new student admission

Teaching and Learning Business Process

This process is a learning process starting from academic policy, following PMB, acceptance of titles, thesis examination, until graduation, table 3, is a teaching and learning business process.

Table 3. The business processes of PMB

No	Name of Sub Process	Detail Activity
2.1	Academic Policy	<ul style="list-style-type: none"> - Organization of academic calendar - Determining the academic advisor (PA) - Determining the instructor - Organizing the schedule, lecture room, and the laboratory - PA Consultation (filling in the KRS and KRS change) - Academic Leave Administration
2.2	Following PBM	<ul style="list-style-type: none"> - Implementation, Monitoring, and PBM Evaluation - Students' data management - Lecturers' data management - Formation of exam committee - Exam implementation - Score Administration - Printing Academic Transcript - Academic Report - On the job training - Implementation of on the job training exam
2.3	Title Acceptance	<ul style="list-style-type: none"> - Proposing the title - Reviewing the title - Determining the advisors and the process of proposal guidance
2.4	Proposal Defense	<ul style="list-style-type: none"> - Implementation of proposal defense - Proposal decision
2.5	Undergraduate thesis defense	<ul style="list-style-type: none"> - The process of undergraduate thesis guidance - The implementation of undergraduate thesis comprehensive defense - The decision of undergraduate thesis defense
2.6	Graduated	<ul style="list-style-type: none"> - Undergraduate thesis revision - Legitimation of undergraduate thesis - Register for judicium and graduation

The Business Process of Graduation

This process is the third process after the student has been declared passed on the thesis examination. The stages in this process start from the release of students to the determination of student status.

Table 4. The Business Process of Graduation

No	Name of Sub Process	Detail Activity
3.1	Students' Graduation	<ul style="list-style-type: none"> - Graduation plan - Forming the graduation committee - Making the Certificate and Score Transcript - Graduation implementation - Reporting the evaluation of graduation activity
3.2	Determining the students' status	<ul style="list-style-type: none"> - Determining the drop out students - Determining the resigned students - Determining graduated students

The Business Process of Alumni and Career

Next are the alumni and career business processes. Here is a grouping of activities from the existing processes and their renewal, shown in table 5.

Table 5. Alumni and Career Business Process

No	Name of Sub Process	Detail Activity
4.1	Alumni Data Collection	<ul style="list-style-type: none"> - Forming the alumni committee - Recording the alumni biodata - Marking the location and work position of the alumni
4.2	Spread of Job Vacancy Information	<ul style="list-style-type: none"> - Management of job vacancy data - Installation of job vacancy announcement

Information System Architecture

This phase describes the information system architecture in which there are several developments in the data architecture and application architecture. In this study, the application architecture is divided into four parts, as shown in table 6. The blue items mean the applications will be developed, whereas the black items had already available on the STMIK Amik Riau campus.

Table 6. Information system architecture

NO	Application Name	Module	Application Code		
1	Promotion and PMB Application	Scheduling the promotion	AP 1.1		
		Managing the data of promotion committee	AP 1.2		
		Managing the promotion activity	AP 1.3		
		Managing the promotion budget	AP 1.4		
		Scheduling PMB	AP 1.5		
		PMB Registration	AP 1.6		
		Management of Selection Score	AP 1.7		
		Making PMB Report	AP 1.8		
		2	PMB Application	e-KTM	AP 2.1
				Correspondence	AP 2.2
Management of students' data	AP 2.3				
Academic Advisor	AP 2.4				
Lecture Schedule	AP 2.5				
e-KRS (Study Plan Card)	AP 2.6				
e-Attendance	AP 2.7				
e-Edom	AP 2.8				
Score management	AP 2.9				
e-KHS (Study Result Card)	AP 2.10				
e-Library	AP 2.11				
e-Learning	AP 2.12				
Complaint Center	AP 2.13				
Laboratory	AP 2.14				
e-Undergraduate Thesis	AP 2.15				
Graduation	AP 2.16				
3	Graduation Application	Certificate and Score Transcript	AP 3.1		
		Graduate Report	AP 3.2		
		The Students' Status	AP 3.3		
4	Alumni and Career Center	e-Alumni	AP 4.1		
		Career Center	AP 4.2		
		Tracer Study	AP 4.3		
		SIG Alumni	AP 4.4		

The development of the data architecture is also seen in Figure 6. The development carried out in this architecture indicates several changes from the previous implementation. The most visible changes are in the cloud data storage and mirror servers.

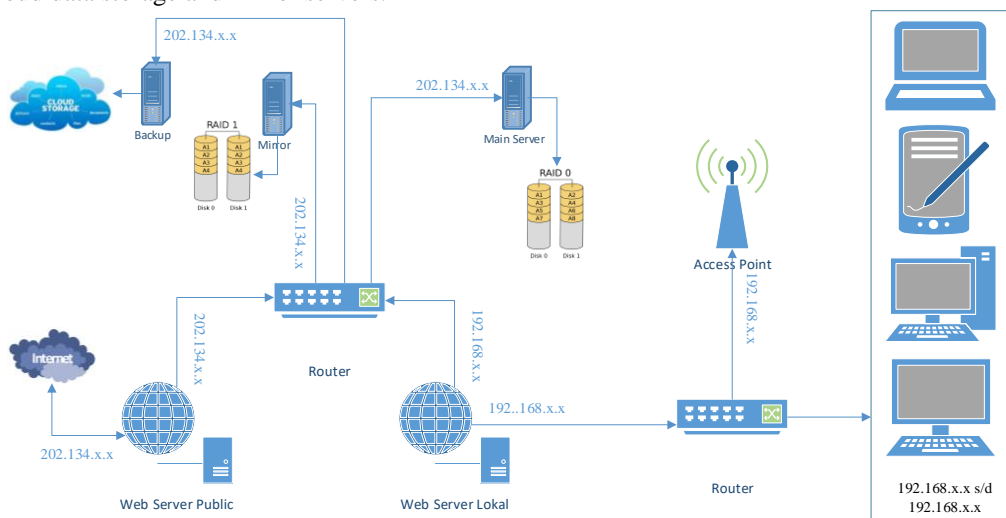

Figure 6. Data architecture

Technology Architecture

This phase describes the development of the technology architecture that will be carried out. In figure 7, it is a technology architecture that developed from previously applied technology. This can be seen from several web services that have been separated and have backups to anticipate unwanted events such as natural disasters, virus attacks, and so on.

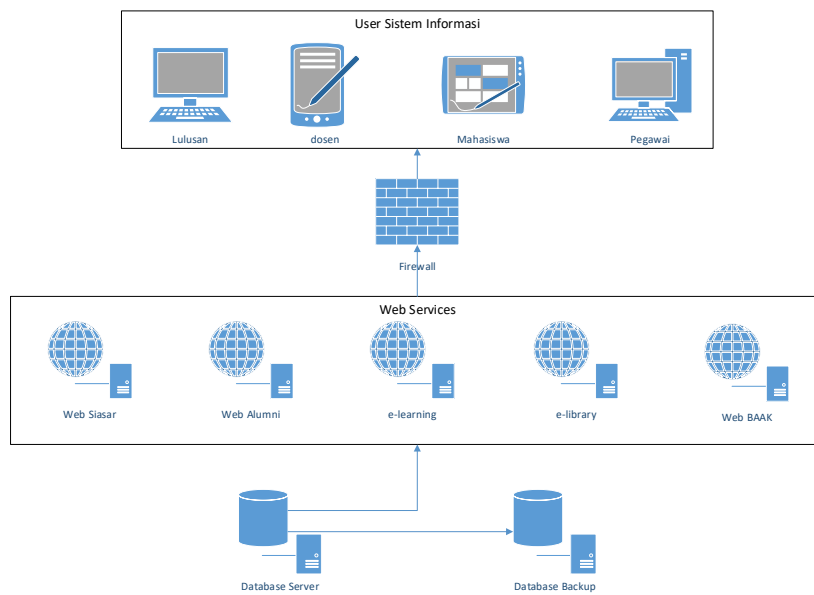

Figure 7. Technology Architecture

Opportunities and Solution

This phase describes the process of identifying projects, programs, or portfolios that effectively provide the target architecture identified in the previous phase.

Table 7. Opportunity and Solution

Architecture	Discrepancy	Potential Solution
Bisnis	<ol style="list-style-type: none"> 1. The implementation of single sign-on is not thorough yet in each system 2. There are still some applications that their usage are not optimal yet (there is still a manual process) 3. The IT support still does not function optimally 	<p>Implementing single sign-on thoroughly</p> <p>Optimizing the system usage fully</p> <p>Optimizing the performance of IT Support.</p>
Data	The data in the databases are not all integrated yet, until some activities that need data are a bit difficult in obtaining the data expected.	Redesigning the existed database by doing join data instruction so that all data can be integrated well.
Application	Some applications are not available yet until the manual work is still frequently done in some activities.	Reupdating the sisfo strategic planning and adding some application system for the unit that needs it.
Technology	<ol style="list-style-type: none"> 1. The server is frequently in trouble. This case causes the frequent occurrence of application system could not be accessed from the outside even from the inside of the campus also often occurred. 2. All webservers are still in one server until if trouble occurs in that server, then all campus services will stop working. 3. There is no good server backup yet, either online or offline. 	<p>Conducting mirror server design so that when the main server is down, the mirror server could run.</p> <p>Conducting separation of webservice to each of its servers.</p> <p>Rent VPN or cloud storage and back up the server data in a different place.</p>

In addition to the solutions offered in this study, there are several strategies that must be considered to support the implementation process. This strategy is used to minimize the risk of failure, the following are strategies that must be noticed [6]:

1. Economic considerations (implementation costs)
2. Human resource development
3. Reducing risks during system development and implementation by:
 - a) Testing the application module that will be applied to the system to be built;
 - b) Documenting the entire information system in a complete and structured manner so that any errors can be easily traced;
 - c) The implementation of information systems is carried out in parallel with several existing applications. If during one implementation period, it runs without resistance then data migration will begin;
 - d) Training for application users;
 - e) Conducting socialization for all stakeholders including students.

Migration Planning

In migration planning, the transition from an existing architecture to the target architecture is conducted by completing a detailed implementation and migration plan. In table 9, it can be seen that there are several parts to carry out this process, namely strategy, high potential, operational keys, and support. This process is a portfolio or blueprint of this research.

Tabel 8. Migration Planning

STRATEGY	HIGH POTENTIAL
- Application of scheduling promotion	- E-Library Application
- Application of promotion committee data management	- E-Learning Application
- Application of promotion activity management	- Tracer Study Application
- Application of PMB Schedule	- SIG Alumni Application
- Application of PMB Registration	- Complaint Center Application
- Application of Making PMB Report	
- Application of Selection Score Management	
- Application of Making PMB Report	
- Application of Students' Data Management	
- Application of Score Management	
- E-KTM (Student ID) Application	- E-Alumni Application
- E-KRS (Study Plan Card) Application	- Career Center Application
- E-KHS (Study Result Card) Application	- Laboratory Application
- E-Attendance Application	- Correspondence Application
- E-Undergraduate Thesis Application	- E-Edom Application
- Graduation Application	
- Academic Advisor Application	
- Certificate and Score Transcript Application	
- Graduate Report Application	
- Students' Status Application	
OPERATIONAL KEY	SUPPORT

Application is one of the most important to produce quality data. Thus, we need to group the application to facilitate adding applications that are not yet available. Then to support the running of applications properly, technology is needed. Technology architecture can be seen in Figure 7.

CONCLUSION

Referring to the findings of this study, it was concluded that the maturity level of STMIK Amik Riau based on the ITIL v3 framework was at the repeatable level or 2. Several things should be done to increase to level 3 as expected by the chairman of STMIK Amik Riau, including the following In the business architecture, the improvements made are to add some detailed activities to overcome the problems that have occurred in student business processes starting from registration to becoming alumni of STMIK Amik Riau. Furthermore, It is known that the technology architecture does not yet have online or offline backups. If there is a problem to the server, then the repair takes a long time. Therefore, data backup and mirror processes are most emphasized in the technology architecture for server stability to run well. After that, several application modules must be added to create good business processes in the information system architecture, especially the application. Moreover, STMIK Amik Riau is suggested to repair gaps for the existing system based on opportunities and solutions. And the last, make improvements or additions to application modules based on the proposed migration planning to know the priorities that must be done first by the programmer. In making improvements as proposed in the IT blueprint obtained, STMIK Amik Riau needs to first improve from the business side. Technology as an infrastructure to run applications or information systems also needs to be improved so that the process can run better. If improvements have been made to both of these, then the next step is to take measurements using Frameworks such as CMMI and ITIL. Thus, business processes for students at STMIK Amik Riau can run effectively and efficiently.

REFERENCES

- [1] Meranti and Irwansyah, "Kajian humas digital: transformasi dan kontribusi industri 4.0 pada strategik kehumasan," *J. Teknol. Inf. dan Komun.*, vol. 7, no. 1, pp. 27–36, 2018.
- [2] Pemerintah Indonesia, *Undang-Undang Republik Indonesia No 22 Tahun 1961 Tentang Perguruan Tinggi*. Indonesia, 1961.
- [3] Musrifah, "Implementasi teknologi informasi menggunakan human organization technology (HOT) fit model di perpustakaan perguruan tinggi," in *Jurnal Ilmu Perpustakaan dan Informasi*, 2017, vol. 2, no. 2, pp. 222–242.
- [4] S. Aswati, N. Mulyani, Y. Siagian, and A. Z. Syah, "Peranan sistem informasi dalam perguruan

- tinggi,” *J. Teknol. dan Sist. Inf.*, vol. 1, no. 2, pp. 79–86, 2015.
- [5] C. A. Rajan and R. Baral, “Adoption of ERP system: An empirical study of factors influencing the usage of ERP and its impact on end user,” *IIMB Manag. Rev.*, vol. 27, no. 2, pp. 105–117, 2015.
- [6] R. Setiawan, “Perancangan arsitektur enterprise untuk perguruan tinggi swasta menggunakan togef ADM,” *J. Algoritm.*, vol. 12, no. 2, pp. 548–561, 2016.
- [7] E. Suseno, “Pemodelan arsitektur enterprise perguruan tinggi dengan metode togef (studi kasus universitas nahdlatul ulama cirebon),” *J. Cloud Inf.*, vol. 1, no. 1, pp. 1–9, 2017.
- [8] Y. Gong and M. Janssen, “The value of and myths about enterprise architecture,” *Int. J. Inf. Manage.*, vol. 46, no. July 2017, pp. 1–9, 2019.
- [9] F. Saleem and B. Fakieh, “Enterprise architecture and organizational benefits: a case study,” *Sustain.*, vol. 12, no. 19, 2020.
- [10] A. A. Sari and A. D. Manuputty, “Perencanaan arsitektur enterprise menggunakan togef adm (architecture development method) pada dinas kesehatan kota salatiga,” in *SESINDO 2018*, 2018, no. November.
- [11] S. Lolo, E. R. Kaburuan, and N. Legowo, “Analysis of enterprise architecture using the togef framework in educational services,” *Int. J. Adv. Sci. Technol.*, vol. 29, no. 5, pp. 3386–3400, 2020.
- [12] N. Anggraini, Binariswanto, and N. Legowo, “Cloud computing adoption strategic planning using ROCCA and TOGAF 9.2: A study in government agency,” *Procedia Comput. Sci.*, vol. 161, pp. 1316–1324, 2019.
- [13] A. Supriatna, “Analisa penerapan togef dan cobit dalam tata kelola teknologi informasi sebagai usulan pada kementerian energi dan sumber daya mineral,” in *Seminar Nasional Informatika*, vol. 2010, no. semnasIF, pp. 1–8, 2010.
- [14] A. Hodijah, S. Sundari, and A. C. Nugraha, “Applying TOGAF for e-government implementation based on service oriented architecture methodology towards good government governance,” *J. Phys. Conf. Ser.*, vol. 1013, p. 012188, 2018.
- [15] A. Y. Eskaluspita and I. D. Sumitra, “The open group architecture framework for designing the enterprise architecture of ALIT,” in *IOP Conf. Ser.: Mater. Sci. Eng.*, 2020, vol. 879, no. 1.
- [16] M. E. L. Baz, M. M. Armand, C. Anong, and B. Mustapha, “ITIL Implementation in a moroccan stat organization : The case of incident management process,” *Int. J. Adv. Eng. Res. Sci.*, vol. 4, no. 4, pp. 71–78, 2017.
- [17] D. Tomar, “TQM , ISO 9000 , Six sigma and CMMI project management in business and technology,” *Softw. Eng.*, vol. 9, no. 1, pp. 1–8, 2020.
- [18] A. Gerber, P. Le Roux, and A. van der Merwe, “Enterprise architecture as explanatory information systems theory for understanding small-and medium-sized enterprise growth,” *Sustain.*, vol. 12, no. 20, pp. 1–31, 2020.
- [19] R. Khayami, “Qualitative characteristics of enterprise architecture,” *Procedia Comput. Sci.*, vol. 3, pp. 1277–1282, 2011.
- [20] F. Gampfer, A. Jürgens, M. Müller, and R. Buchkremer, “Past, current and future trends in enterprise architecture—A view beyond the horizon,” *Comput. Ind.*, vol. 100, pp. 70–84, 2018.
- [21] A. Josey, “An introduction to the TOGAF® standard, version 9.2,” *The Open Group*, no. April, The Open Group, Reading, UK, p. 22, 2018.
- [22] S. Kotusev, “TOGAF Version 9 . 2 : What ’ s New?,” *Br. Comput. Soc.*, no. June, pp. 1–4, 2018.
- [23] S. Husein and A. N. Fajar, “Design of a cloud based information system for education institution using TOGAF ADM,” *Int. J. Recent Technol. Eng.*, vol. 8, no. 6, pp. 279–285, 2020.
- [24] H. Supriadi and E. Amalia, “University’s enterprise architecture design using enterprise architecture planning (EAP) based on the Zachman’s framework approach,” *Int. J. High. Educ.*, vol. 8, no. 3, pp. 13–28, 2019.
- [25] G. F. Nama, Tristiyanto, and Di. Kurniawan, “An enterprise architecture planning for higher education using the open group architecture framework (togaf): case study University of Lampung,” in *Proceedings of the 2nd International Conference on Informatics and Computing, ICIC 2017*, 2018, vol. 2018-Janua, pp. 1–6.
- [26] Holilah, A. S. Girsang, and M. H. Saragih, “Designing IT blue print academic system on higher education with Togaf,” *Adv. Sci. Technol. Eng. Syst.*, vol. 4, no. 2, pp. 244–250, 2019.
- [27] A. G. Tuwondila, M. N. N. Sitokdana, and A. F. Wijaya, “Perencanaan strategis SI/ TI pemerintahan menggunakan the open group architecture framework (TOGAF),” in *Semin. Nas. Sist. Inf. Indones.* November, 2018, pp. 1–6.
- [28] D. N. Murti, Y. A. Prasetyo, and A. A. N. Fajrillah, “Perancangan enterprise architecture pada fungsi sumber daya manusia (sdm) di universitas telkom menggunakan togef ADM,” *J. Rekayasa*

- Sist. Ind.*, vol. 4, no. 1, pp. 47–55, 2017.
- [29] B. Noranita, D. M. K. Nugraheni, M. I. Fitriyani, and Y. Nurhayati, “Business architecture and information system architecture design in savings and payment unit Koperasi Pegawai Republik Indonesia (KPRI) Diponegoro University using TOGAF 9 framework,” in *Journal of Physics: Conference Series*, vol. 1943, no. 1, pp. 1–24, 2021.
- [30] C. Gellweiler, “Types of IT architects: A content analysis on tasks and skills,” *J. Theor. Appl. Electron. Commer. Res.*, vol. 15, no. 2, pp. 15–37, 2020.
- [31] M. Sidiq and I. D. Sumitra, “Strategic information systems planning using the togaf Architecture Development Method,” *IOP Conf. Ser. Mater. Sci. Eng.*, vol. 662, no. 2, p. 022057, 2019.
- [32] S. A. Wulandari, A. P. Dewi, M. R. Pohan, D. I. Sensuse, M. Mishbah, and Syamsudin, “Risk assessment and recommendation strategy based on COBIT 5 for risk: Case study SIKN JIKN helpdesk service,” *Procedia Comput. Sci.*, vol. 161, pp. 168–177, 2019.
- [33] H. M. Astuti, F. A. Muqtadiroh, E. W. Tyas Darmaningrat, and C. U. Putri, “Risks assessment of information technology processes based on COBIT 5 framework: A case study of ITS service desk,” *Procedia Comput. Sci.*, vol. 124, pp. 569–576, 2017.
- [34] C. Silva, P. Ribeiro, E. B. Pinto, and P. Monteiro, “Maturity model for collaborative R&D university-industry sustainable partnerships,” *Procedia Comput. Sci.*, vol. 181, pp. 811–817, 2021.
- [35] E. S. Pane and R. Sarno, “Capability Maturity Model Integration (CMMI) for Optimizing Object-Oriented Analysis and Design (OOAD),” *Procedia Comput. Sci.*, vol. 72, no. Cmmi, pp. 40–48, 2015.
- [36] S. Sitinjak, “Pengukuran tingkat kematangan keselarasan strategi teknologi informasi dan bisnis badan kepegawaian daerah provinsi ...,” in *Soliter*, 2019, vol. 2, pp. 143–152, [Online]. Available: <https://www.soliter.ulm.ac.id/index.php/soliter/article/view/63>.
- [37] M. Gërvalla, N. Preniqi, and P. Kopacek, “IT infrastructure library (ITIL) framework approach to IT governance,” in *IFAC-PapersOnLine*, 2018, vol. 51, no. 30, pp. 181–185.
- [38] N. Ahmad and Z. M. Shamsudin, “Systematic approach to successful implementation of ITIL,” *Procedia Comput. Sci.*, vol. 17, pp. 237–244, 2013.
- [39] N. H. Harani, A. A. Arman, and R. M. Awangga, “Improving TOGAF ADM 9.1 Migration Planning Phase by ITIL V3 Service Transition,” in *J. Phys.: Conf. Ser.*, 2018, vol. 1007, no. 1.
- [40] O. N. Putra and S. Kuswayati, “Penerapan togaf ADM dan ITIL dalam pengembangan enterperise architecture,” *Media Inform.*, vol. 16, no. 2, pp. 82–90, 2017.
- [41] T. Van Sante and J. Ermers, *ITIL ® and TOGAF ® 9.1: two frameworks*, no. August. 2013.
- [42] A. Cartlidge *et al.*, *An Introductory Overview of ITIL®2011*, This versi. London: TSO (The Stationery Office), 2011.
- [43] M. K. Anam, N. Lizarti, and A. N. Ulfah, “Analisa tingkat kematangan sistem informasi akademik STMIK amik riau menggunakan ITIL v3 domain service operation,” *Fountain Informatics J.*, vol. 4, no. 1, 2019.
- [44] The Open Group, “The TOGAF® Standard, Version 9.2,” *pubs.opengroup.org*, 2018. <https://pubs.opengroup.org/architecture/togaf92-doc/arch/> (accessed May 29, 2020).
- [45] H. Santoso, A. Rasidi, and M. R. Arif, “Perencanaan arsitektur enterpise sistem informasi untuk perguruan tinggi dengan zachman framework,” *Res. Comput. Inf. Syst. Technol. Manag.*, vol. 1, no. 2, p. 32, 2018.
- [46] L. Anastasiu, “The importance of applying the value chain analysis in the higher education system,” in *Int. Conf. Appl. Res. bus. Manag. Econ.*, 2019, pp. 2–13.