

Engineering Perspective and Economic Evaluation of the Synthesis Zinc Oxide Nanopowder by Co-Precipitation Method

Jurnal Scientia Indonesia

2015, Vol. 1(2) 83-100

© The Author(s) 2015

[10.15294/jsi.v8i1.35944](https://doi.org/10.15294/jsi.v8i1.35944)

This journal has been accredited by Ministry of Education, Culture, Research & Technology of Republic Indonesia ([Rank SINTA 6](#)).

Published biannually by:



All writings published in this journal are personal views of the author(s) and do not represent the views of this journal and the author's affiliated institutions. Author(s) retain copyrights under the license of [Creative Common Attribution 4.0 International \(CC BY 4.0\)](#)

Yeni Nurahmawati

Universitas Pendidikan Indonesia
Bandung, Jawa Barat, Indonesia

Asep Bayu Dani Nandiyanto

Universitas Pendidikan Indonesia
Bandung, Jawa Barat, Indonesia
nandiyanto@upi.edu

History of Manuscript

Submitted :
Revised 1 :
Revised 2 :
Accepted :
Online since :

Abstract

The purpose of this study is to evaluate the engineering and economic evaluation of the manufacture of zinc oxide (ZnO) nanopowder by coprecipitation method. Economic evaluation is carried out with several parameters such as: GPM (Gross Profit Margin), PBP (Payback Period), and CNPV (Cumulative net present value) based on simple mathematical calculations using the Microsoft Excel Application. From the project feasibility test it was found that the project suffer a financial loss if the tax paid was 100% and the selling price was less than 90%. The project can produce as many as 1,1017 tons/year of ZnO

nanopowder. ZnO nanopowder production can provide benefits up to 76%. Economic evaluations show positive results because the payback period (PBP) occurs around the 4th year, and profits will continue to increase until the 20th year. Thus, the production of ZnO nanopowder can be considered a lucrative project.

Keywords: Zinc oxide nanopowder, economic evaluation, feasibility study

A. Introduction

Zinc oxide (ZnO) is an inorganic compound used in solar energy conversion and catalysis applications (Al-Gaashani, R. *et al*, 2013), such as electrostatic dissipative coatings, transparent UV protective films and chemical sensors (Liu, M. *et al*, 2011), gas sensors (Ling, Z. *et al*, 2011), antibacterial for medical products (Raghupathi, K.R. *et al*, 2011) (Zhang, L. *et al*, 2006), cosmetics (Vaezi, M.R. *et al*, 2007)

ZnO nanomaterials can be synthesized by various chemicals and methods such as coprecipitation (Yusan S. *et al*, 2016), sol-gel (Yan C. *et al*, 2006), solvo / hydrothermal (Pan A. *et al*, 2005), chemical vapor deposition (Wu J-J. *et al*, 2002) and spray pyrolysis (Ghaffarian H. *et al*, 2011). Of the several methods, the most efficient is the co-precipitation method because the co-precipitation method only requires another material in synthesizing the precipitation agent which is economically very affordable. However, there is no economic evacuation analysis in this study. So, the economic evaluation analysis is very important to do to design an industry.

Therefore, the purpose of this study is to evaluate the engineering and economic evaluation of the manufacture of zinc oxide nanopowder (ZnO) by coprecipitation method. To achieve this goal, we have changed the scale of the ZnO synthesis lab into an industrial scale. And the analysis is carried out by

varying various industry conditions when there are changes in selling prices, taxes and variable costs such as prices of raw materials, utilities and employee salaries.

B. Methods

Figure 1 is a flowchart of ZnO nanopowder synthesis by coprecipitation method based on literature (Yusan, S. *et al*, 2016).

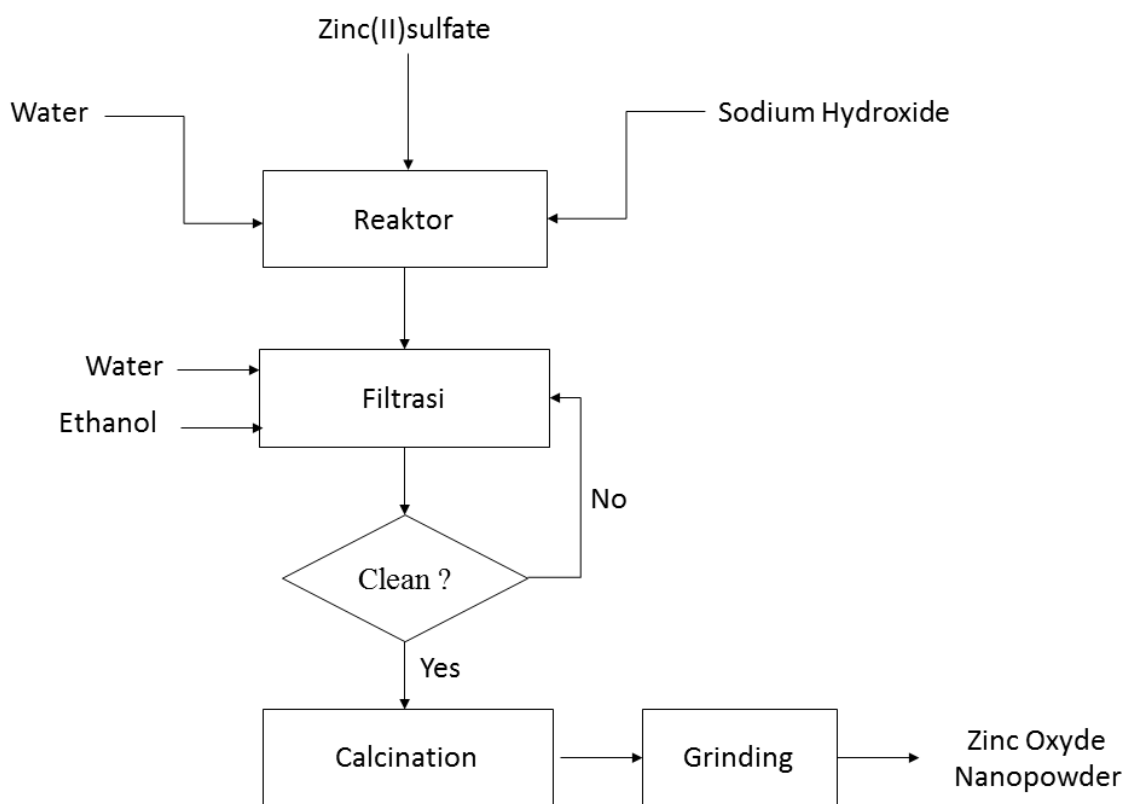

FIGURE 1
Flowchart synthesis ZnO nanopowder with co-precipitation method

The method used in this research is based on the analysis of material prices, equipment prices, and equipment specifications sourced from the online shopping web. Data processing is done by simple mathematical calculations using Microsoft Excel applications to obtain economic evaluation parameters, such as: GPM, PBP, and CNPV with various price variables. Economic evaluation parameters are calculated based on literature (Nandiyanto, 2018)

- a. The Gross Profit Margin (GPM) value can describe the business that is running a loss or profit, if the GPM value is positive then the business is profitable and vice versa if the GPM value is negative then the business is losing money. GPM can be calculated by reducing sales results and raw material costs.
- b. Payback Period (PBP) is a calculation carried out to predict the length of time required to return the initial capital. The intersection of the x-axis on the CNPV / TIC curve with respect to time (years) shows the PBP value
- c. Cumulative net present value (CNPV) is a value that predicts the condition of a production project in the form of a production function in a year. CNPV value is obtained from the net present value (NPV) at a certain time. NPV is the value that represents the expenses and income of a business. In short, CNPV is obtained by adding the NPV value from the first project to the end of the NPV mill operation calculated by adding a discount factor to the calculation of multiplying cash flow.
- d. Break even point (BEP) illustrates the minimum production capacity requirements. The BEP value is calculated by dividing fixed costs by profits.
- e. Profitability index (PI) is an index used to identify the relationship between project costs and impacts. PI can be calculated by dividing the CNPV with the total investment cost (TIC). If the PI is less than 1, then the project can be classified as a non-use project and if the PI is more than 1, then the project can be classified as a good project.

Several assumptions are used in the synthesis of ZnO nanopowder based on stoichiometric calculations:

- All chemical compositions used for the production of ZnO nanoparticles are increased up to 10000 times, the materials used have high purity, and are calculated based on the literature (Yusan S *et al*, 2016).
- $\text{ZnSO}_4 \cdot 7\text{H}_2\text{O}$ is reacted with NaOH using a water solvent and CTAB catalyst.
- $\text{ZnSO}_4 \cdot 7\text{H}_2\text{O}$ and NaOH are reacted in a ratio of 1:20. It is assumed that both of them will react

- The conversion rate for all reactions is 100% with a mass loss in each transfer process that is 2.5%.

Meanwhile, to analyze economic evaluation, several assumptions are used:

- The exchange rate of USD (American currency) against IDR (Indonesian currency) has been set at 1 USD = IDR 14000, (Bank Indonesia, 2018)
 - Projects a year are 300 days and the rest are days used to clean and manage the process.
 - Prices of raw materials obtained from the online shopping web, respectively for zinc (II) sulfate, sodiumhydroxide, cetyltrimethylammonium bromide (CTAB), ethanol, and water are 128.57 USD / kg, 3.57 USD / kg, 502.86 USD / kg, 3.86 USD / L and 0.50 USD / L.
 - The amount of material used in production refers to stoichiometric calculations
 - In 1 day the production of ZnO nanoparticles takes 12 hours of production and produces 3,672 kg of ZnO nanopowder
 - ZnO Nanopartike is sold at 10.71 USD per pack (10 grams)
 - Utility units can be explained and converted as electricity units such as kWh, then the electricity units are converted to costs by multiplying the electricity costs.
 - The electricity fee charged is 0.11 USD / kWh, in one day the electricity fee to be paid is 41.46 USD
 - Total wages / labor is assumed with a fixed value of 150 USD / day.
 - The discount rate is 15% and income tax is 10% every year.
 - Projects carried out for 20 years.
 - Material and equipment delivery costs are eliminated in the calculation
 - Total Investment Cost (TIC) is calculated based on Lang Factor (Nandiyanto *et al*, 2018).
 - TIC is prepared in at least two steps. The first step is 40% in the first year and the second step is the rest (during project construction).
 - Land purchased. As such, land costs are added at the beginning of the factory construction year and recovered at the end of the project.
 - Depreciation is estimated using direct calculation (D.E. Garrett, 2012)
- Variations in economic evaluation are carried out to test the feasibility of the

project with various conditions, namely when there are changes in sales prices, taxes and variable costs such as the price of raw materials, utilities and employee salaries. Tax variations are made in the range of 10% -100%. Variations in sales, raw materials, utilities and employee salaries are made in the range of 80% -120%.

C. Results & Discussion

1. Engineering perspective

Figure 2 show the process of ZnO nanopowder synthesis by the direct precipitation method. The materials used for the synthesis of ZnO nanopowder are zinc (II) sulfate ($ZnSO_4 \cdot 7H_2O$), sodiumhydroxide (NaOH), cetyltrimethylammonium bromide (CTAB), water and ethanol. The ZnO nanopowder synthesis process was taken from (Yusan *et al*, 2016). While the tools used are 100L CSTR reactor, filter press, 198L furnace and grinding machine.

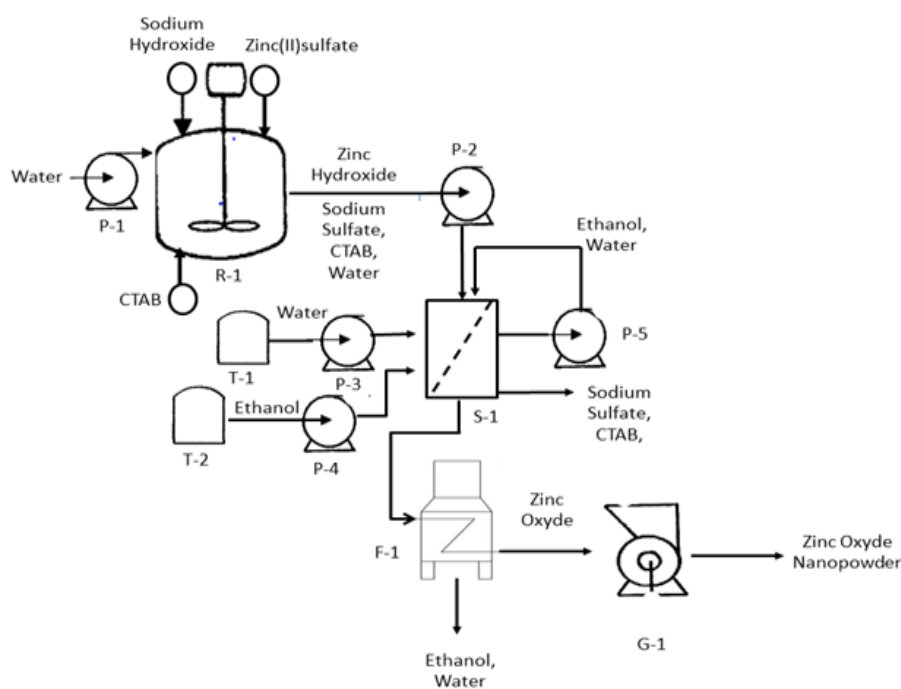

Information :

P-1 : Pump 1	P-5 : Pump 5	G-1: Grinding
P-2 : Pump 2	R-1 : Reaktor	T-1 : Tank 1
P-3 : Pump 3	S-1 : Separator (Filtrasi)	T-2 : Tank 2
P-4 : Pump 4	F-1 : Furnace	

FIGURE 2

Process Flow Diagram of Synthesis ZnO nanopowder

Based on Figure 2 zinc (II) sulfate ($\text{ZnSO}_4 \cdot 7\text{H}_2\text{O}$), sodiumhydroxide (NaOH), cetyltrimethylammonium bromide (CTAB) and water reacted in the reactor for 3 hours with automatic stirring at room temperature. After that, the mixture is allowed to stand for 2 hours to get a solid containing $\text{Zn}(\text{OH})_2$. Then the results of the reactor are filtered using a filter press so that the solid $\text{Zn}(\text{OH})_2$ is separated from the solvent. Then the solids from the filtration are washed using water and ethanol with the aim of removing residual substances from the reaction. The washed solid is put into the furnace at $60\text{ }^\circ\text{C}$ for 1 hour and at $550\text{ }^\circ\text{C}$ for 2 hours. Heating using a furnace aims to evaporate the ethanol and water that remains in the ZnO solids. ZnO solids free from water and ethanol are pulverized using a grinding machine with the aim of forming ZnO nanopowder.

From a technical point of view, it is possible to make more improvements. This increase can occur because the scaling process can be implemented using commercially available and inexpensive equipment. In addition, by calculating projects with 300 processing cycles per year, the suggested scheme is a perspective to produce about 1,1017 tons of ZnO nanopowder by consuming 4,313 tons of zinc (II) sulfate ($\text{ZnSO}_4 \cdot 7\text{H}_2\text{O}$), 12 tons of sodiumhydroxide (NaOH), 2 18 kg of cetyltrimethylammonium bromide (CTAB), 40500L of water and 450L of ethanol ($\text{C}_2\text{H}_5\text{OH}$) per year in ideal conditions. With a total cost to be paid for raw materials for 1 year is 627,253 USD with sales in 1 year 1,180,358 USD so as to obtain a profit of 281,206 USD or equivalent to 76%. Then, analysis of total equipment costs requires a total cost of 72,429 USD. Adding the Lang Factor to the calculation, the TIC must be less than 321,283 USD. This value is relatively economical, and this project requires less investment funds. With a project life span of 20 years by producing 1.1017 tons of ZnO nanopowder with CNPV / TIC it reached 2.97% in the 20th year with PBP around the 4th year.

2. Ideal conditions

Figure 3 shows a graph of the relationship between the x-axis (time) and the y-axis (CNPV / TIC (%)) with various economic evaluation parameters under ideal conditions. The graph decreased in year 0 to year 2. Economic evaluation shows positive results. The payback period (PBP) occurs around

the 4th year, and profits will continue to increase until the 20th year with a CNPV / TIC value of 2.97%. Thus, the production of ZnO nanopowder can be considered a lucrative project.

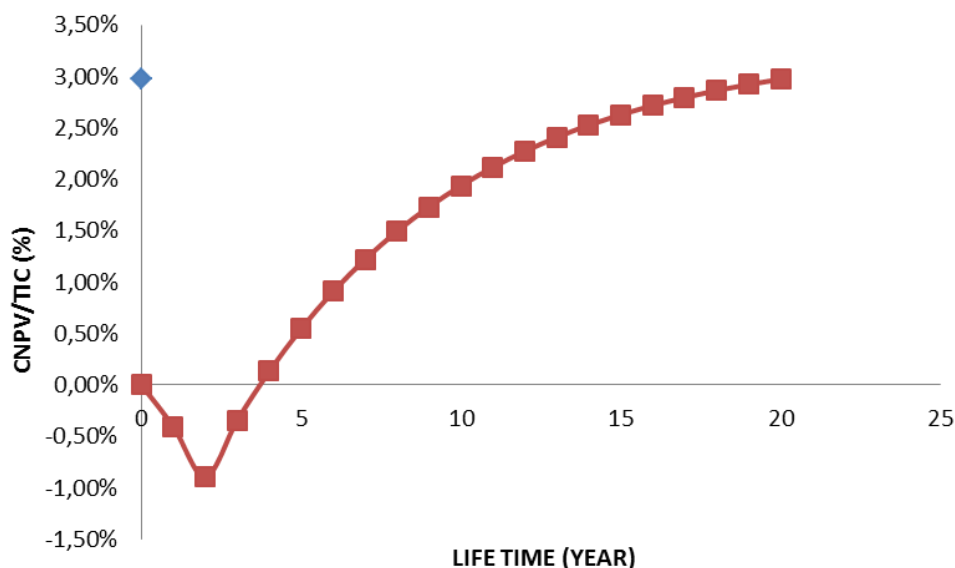

FIGURE 3

Ideal condition for CNPV/TIC to Life Time (year)

Decrease in year 0 to year 2 occurred because in that year related to the function of the tool, so it needed initial capital to buy the tools needed to run this project. In addition, initial capital is needed to buy land and build industry. The payback period (PBP) occurs around the 4th year with a CNPV / TIC value of 0.13%. While profits continue to increase from year 3 to year 20 with a CNPV / TIC value of -0.89% to 2.97%. This happened because in the 3rd year ZnO nanopowder could be sold and the initial capital had been returned, so the sales value of Rp. 16,525,017,235,268 per year. The graph continued to improve until the 20th year, because the production of ZnO nanopowder was stable so that income was stable. In addition, the production of zinc oxide nanopowder can provide benefits of up to 76%.

Thus, the production of ZnO nanopowder can be considered a profitable project because it takes a short time to return the initial capital and stable income in the 20th year.

3. External influence

The stability of the project can be disrupted by external factors such as taxes and sales. Therefore, tax variations and sales variations are carried out in order to test the feasibility of the project.

Figure 4 shows a graph of the relationship between the x-axis, which is time (years) and the y-axis (CNPV / TIC (%)) with the effect of tax changes. The analysis was carried out with variations in taxes that had to be paid, namely 25%, 50%, 75% and 100%. The graph decrease in various tax variations is relatively the same as the graph decrease in ideal conditions (year 0 to year 2) because it is related to the function of tools and industrial development. The greater the tax that must be paid, the more sloping graph increase. The increase in taxes to be paid also affects the payback period (PBP). The greater the tax that must be paid, the PBP will be achieved in a longer period of time. PBP value is reached around the 5th, 6th and 11th years with tax that must be paid in a row that is 25%, 50% and 75%. If the tax paid is 100%, no PBP will be reached. The graph continues to increase from around the 3rd year until the 20th year.

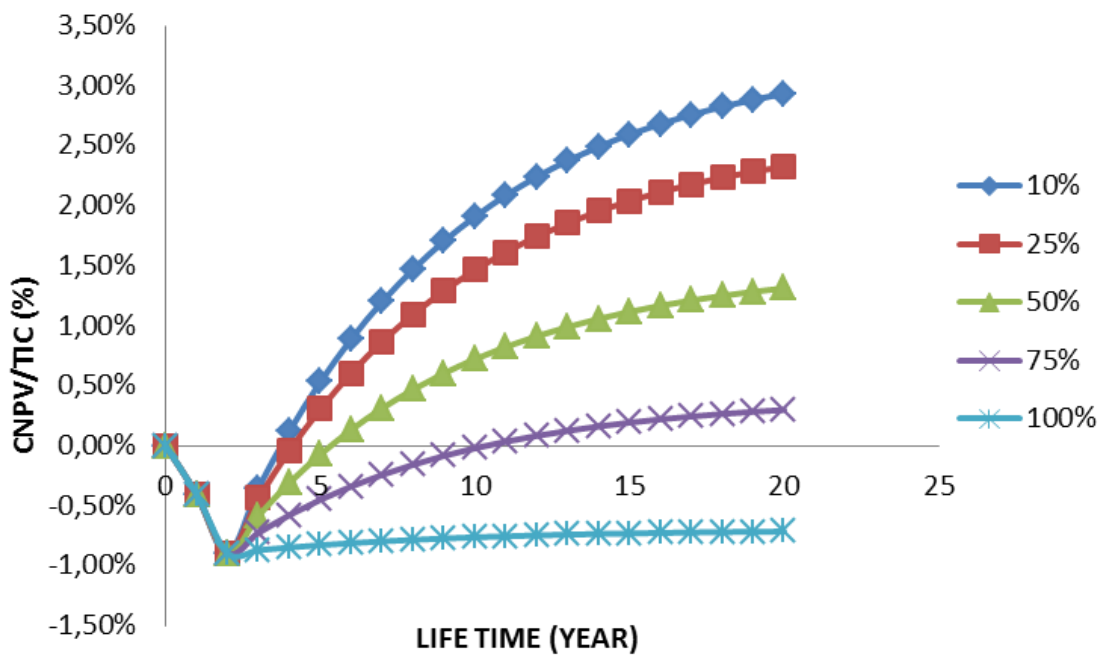

FIGURE 4
CNPV curves under tax

Based on the graph, taxes to be paid affect the CNPV chart. The greater the tax that must be paid, the profit from the business being run decreases. With tax paid 25%, 50% and 75% respectively PBP was achieved around the 5th, 6th, and 11th years. If the tax paid was 100%, PBP was not achieved because the project suffered a loss. PBP shift to the right occurs because the tax that must be paid every year is getting bigger. Thus, the profit is still ideally obtained if the tax paid is 25% because PBP is still achieved around the 5th year. If the tax paid is more than 25%, the profit of the project decreases and suffers losses if the tax to be paid is 100%. According to (Miftahurrahman *et al*, 2019) if the tax is very high then the production of gold nanoparticles is not profitable. From the results obtained in accordance with the literature (Miftahurrahman *et al*, 2019) because the project suffered a loss if the tax must be paid at 100%.

Figure 5 shows a graph of the relationship between the x-axis, which is time (years) and the y-axis (CNPV / TIC (%)) with the effect of changes in selling prices. The analysis was carried out with variations in selling prices of 80%, 90%, 110% and 120%. The graph decline in various variations of selling prices is not different from the graph decline in ideal conditions (in years 0 to 2) because it is related to the function of tools and industrial development. The addition of selling prices to 120% and 110% causes the increase in the chart to get steeper. While the decline in selling prices amounted to 80% and 90% causing an increase in the sloping graph. The decrease in selling price also affects the return period (PBP). PBP value is reached around the 3rd, 4th and 6th year with the selling price respectively 120%, 110% and 90%. If the selling price becomes 80%, PBP will not be reached. The greater the selling price, the PBP will be achieved at a faster time. And the smaller the selling price, the PBP will be achieved in a longer time. From the economic evaluation of (Nandatamadini *et al*, 2019) on the sale of Co nanoparticles will be profitable if the selling price increases more than 100% because it shows a positive GPM value. PBP value is related to the value of GPM, the greater the value of GPM, the faster the PBP is reached. From the results obtained in accordance with the literature (Nandatamadini *et al*, 2019) because the greater the selling price, the greater the value of GPM and causes PBP to be achieved faster.

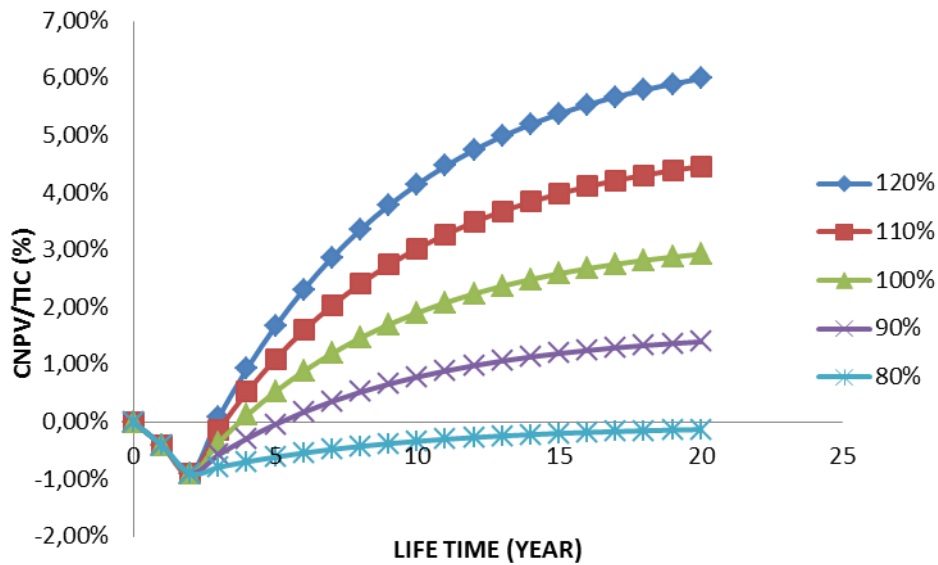

FIGURE 5
CNPV curves under various sales

Based on the graph, the selling price affects the CNPV curve. The smaller the selling price, the profit from the business being run decreases. And the greater the selling price, the profits from the business being run increasingly increased. With a selling price of 120%, 110% and 90% respectively PBP is achieved around the 3rd, 4th and 5th years. If the selling price becomes 80%, PBP will not be reached because the project has a loss. PBP shift to the right occurs because the selling price decreases, so that the value of CNPV / TIC decreases. While the PBP shift to the left occurs because the selling price is increasing, so the value of CNPV / TIC is increasing. The addition of selling prices to 120% and 110% causes the increase in the chart to get steeper because the CNPV / TIC value is getting bigger. While the decline in selling prices to 80% and 90% causes an increase in the sloping graph, because it causes the CNPV / TIC value to decrease. Thus, the profit is still obtained ideally if the selling price is 90% because PBP is still achieved around the 5th year. If the selling price is less than 90%, the project will suffer a loss.

4. Influence of variable costs (raw materials, utilities and employee salaries)

The stability of the project can also be disrupted by the influence of variable costs such as raw material prices, utilities and employee salaries. Therefore, variations in the prices of raw materials, utilities and employee salaries are carried out in order to test the feasibility of the project.

Figure 6 shows a graph of the relationship between the x-axis (time) and the y-axis (CNPV / TIC (%)) with the effect of changes in raw material prices. The analysis was carried out with variations in raw materials by 80%, 90%, 110% and 120%. The graph decrease in various variations of raw material prices is not different from the graph decline in ideal conditions (in the 0 to 2 years) because it is related to the function of tools and industrial development. The addition of raw material prices to 120% and 110% has caused the graph to rise even steeper. While the decline in raw material prices to 80% and 90% caused an increase in the sloping graph. The decrease in selling price also affects the return period (PBP). PBP value is reached around the 2.5, 3, 4 and 5 years with the prices of raw materials respectively 120%, 110%, 90% and 80%. The greater the price of raw materials, the PBP will be achieved in a longer time. And the smaller the selling price, the PBP will be achieved at a faster time. According to (Shalahuddin *et al*, 2019) A decrease in variable costs results in a high final CNPV value and by increasing variable costs, the CNPV value decreases. The results obtained are in accordance with the literature (Shalahuddin *et al*, 2019) because if the final CNPV value decreases it will cause PBP to be reached longer and if the final CNPV value increases it will cause PBP to be reached more quickly.

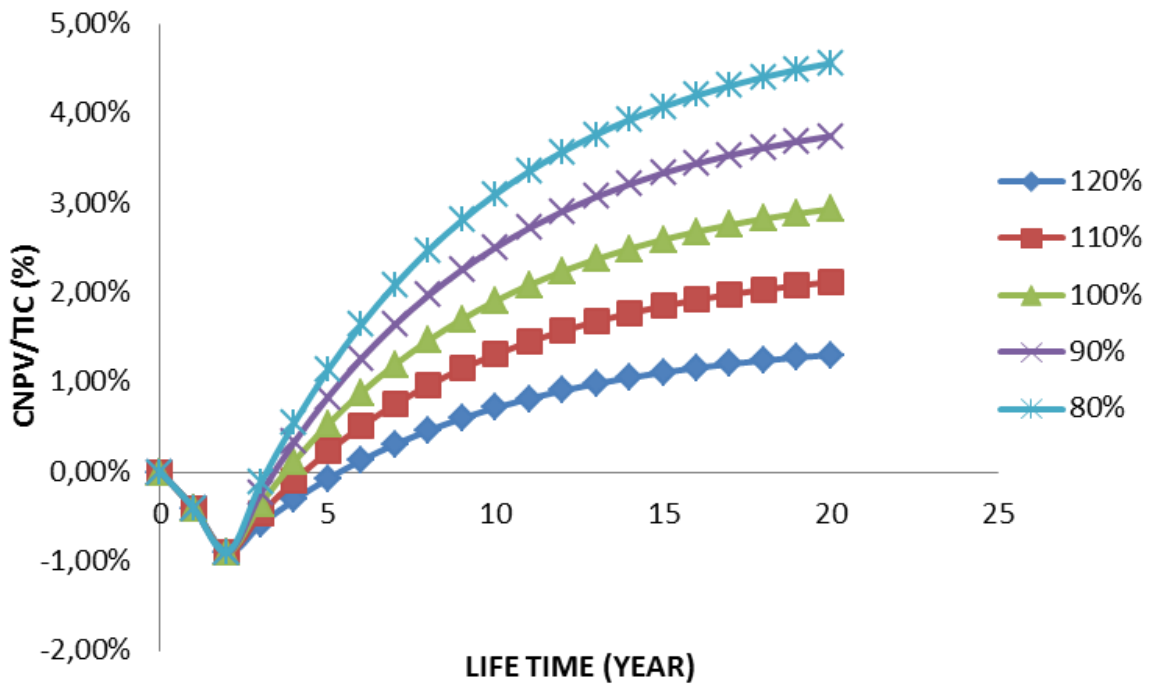

FIGURE 6
CNPV curves under various raw material

Based on the graph, raw material prices affect the CNPV curve. The smaller the price of raw materials, the profits from the business being run increasingly increased. And the greater the price of raw materials, the profits from the business being run decreases. With raw material prices of 120%, 110%, 90% and 80% respectively PBP was achieved around the 2.5, 3, 4 and 5 years. The PBP shift towards the right occurred because the price of raw materials was decreasing, so the value of CNPV / TIC is also declining. While the PBP shift to the left occurs because the price of raw materials has increased, so that the value of CNPV / TIC has also increased. The addition of raw material prices to 120% and 110% causes a rise in the sloping chart because the CNPV / TIC value is getting smaller. Whereas the decrease in raw material prices to 80% and 90% causes the graph to rise even steeper, because it causes the CNPV / TIC value to increase. From the variations, the project can still run and benefit because the CNPV value is positive. From the economic evaluation results (Prabowo *et al*, 2018) the benefits can be obtained if the variable costs vary at a maximum value

of less than 150%. The results obtained are in accordance with reference (Prabowo *et al*, 2018) because variations in raw material prices are less than 150%.

Figure 7 show a graph of the relationship between the x-axis, which is time (years) and the y-axis (CNPV / TIC (%)) with the effect of changes in utility. The analysis was performed with utility variations of 80%, 90%, 110% and 120%. The graph decrease in various utility variations is not different from the graph decrease in ideal conditions (in the 0-to-2 years) because it is related to the function of tools and industrial development. The increase in graphs and PBP values for all utility variations is relatively the same. The payback period (PBP) occurs around the 4th year, and profits will continue to increase until the 20th year with CNPV / TIC values of 2.89%, 2.91%, 2.93% and 2.97% for successive utilities - according to 120%, 110%, 90% and 80%. According to Shalahuddin *et al* [18] Decreasing variable costs results in a high final CNPV value and by increasing variable costs the CNPV value decreases.

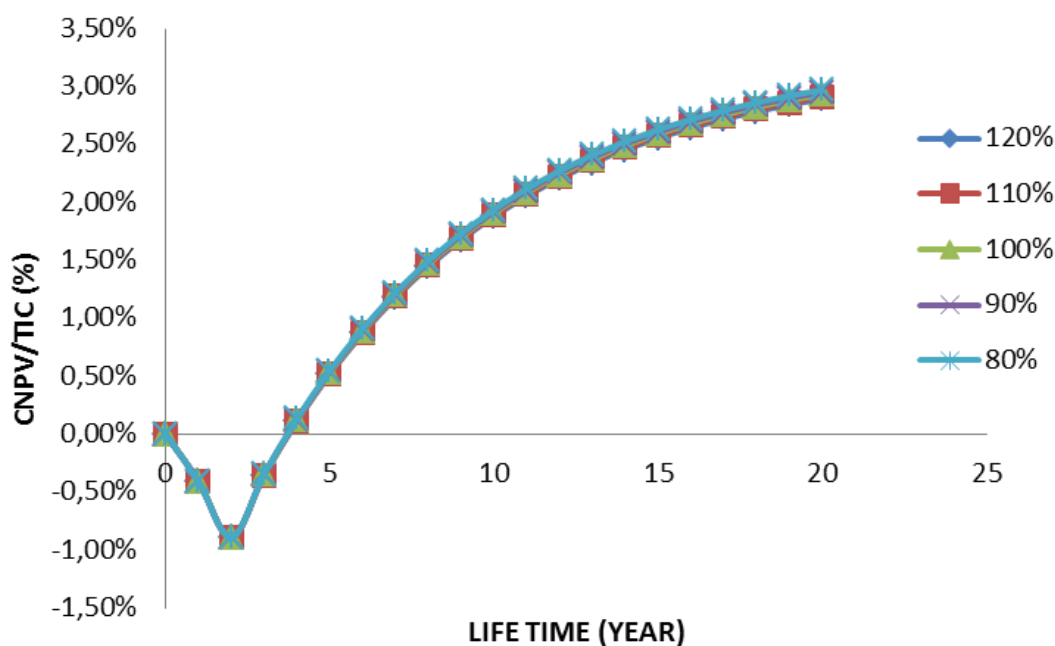

FIGURE 7
CNPV curves under various utilitas

Based on the graph, utility has no effect on the CNPV curve because the percentage of expenditure for utilities is around 0.04% of profit. Therefore, the project can run and benefit with a variety of utilities.

Figure 8 show a graph of the relationship between the x-axis, which is time (years) and the y-axis, namely CNPV / TIC (%) and the effect of changes in employee salaries. The analysis was performed with variations in employee salaries of 80%, 90%, 110% and 120%. The graph decrease in various variations of employee salaries is not different from the graph decrease in ideal conditions (in the 0-to-2 years) because it is related to the function of equipment and industrial development. The increase in graphs and PBP values for all variations of employee salaries was relatively the same. The payback period (PBP) occurs around the 4th year, and profits will continue to increase until the 20th year with CNPV / TIC values of 2.82%, 2.88%, 2.99% and 3.05% for employee salaries respectively 120%, 110%, 90% and 80%. According to (Shalahuddin *et al*, 2019) Decreasing variable costs results in a high final CNPV value and by increasing variable costs the CNPV value decreases.

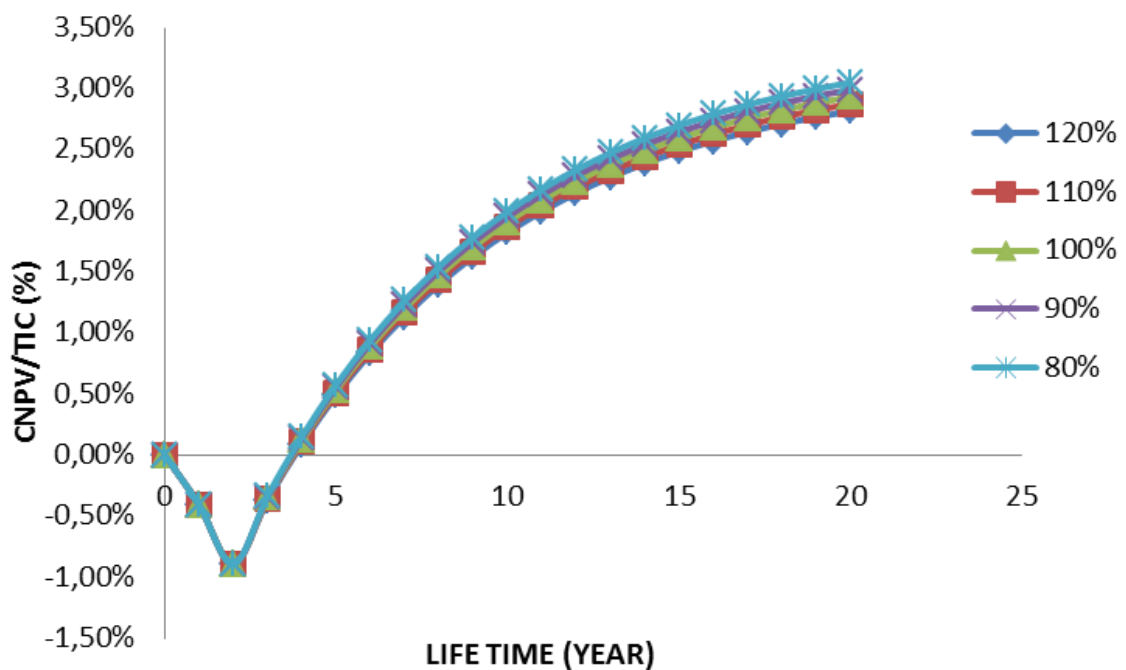

FIGURE 8
CNPV curves under various labor

Based on the graph, employee salaries have no effect on the CNPV curve because the percentage of expenses for employee salaries is around 0.16% of profits. From the economic evaluation results (Prabowo *et al*, 2018) the benefits

can be obtained if the variable costs vary at a maximum value of less than 150%. Therefore, the project can run and benefit with a variety of utilities that are less than 150%.

D. Conclusion

From the analysis, it was found that the project could produce ZnO nanopowder as much as 1.1017 tons per year using inexpensive and available materials and tools. From the economic evaluation it was found that the production of ZnO nanopowder could provide benefits up to 76%. Economic evaluations show positive results because the payback period (PBP) occurs around the 4th year, and profits will continue to increase until the 20th year with a CNPV / TIC value of 2.97%. Thus, the production of ZnO nanopowder can be considered a lucrative project.

E. Acknowledgments

None

F. Declaration of Conflicting Interests

Authors state there is no conflict of interests in this research and or publication of his work.

G. Funding Information

None

H. References

- A.B.D. Nandiyanto, Ragadhita, R, Maulana, A, and Abdullah, A. (2018). Feasibility Study on the Production of Biogas in Dairy Farming. *IOP Conference Series: Material Science and Engineering*. 288, pp. 012024.

-
- Bank Indonesia. "Foreign Exchange Rates". <https://www.bi.go.id/en/moneter/informasi-kurs/referensi-jisdor/Default.aspx>, Apr, (2018).
- B. Prabowo, Khairunnisa, T. and Nandiyanto, A. B. D. (2018). Economic Perspective in the Production of Magnetite (Fe₃O₄) Nanoparticles by Co-precipitation Method. *World Chemical Engineering Journal* Vol. 2, No. 2, (2018), pp. 1 – 4
- D.E. Garrett. (2012). *Chemical Engineering Economics*. Springer Science & Business Media, New York.
- F.A. Shalahuddin, Almekahdinah, S.S. and Nandiyanto, A. B. D. (2019). Preliminary Economic Study on the Production of ZnO Nanoparticles Using a Sol-Gel Synthesis Method. *Indonesian Journal of Applied Chemistry*. 21(1), pp. 01 – 06
- F.Nandatamadini, Karina, S. and Nandiyanto, A. B. D. (2019). Feasibility study based on economic perspective of cobalt nanoparticle synthesis with chemical reduction method. *Cakra Kimia (Indonesian E-Journal of Applied Chemistry)* Volume 7 Nomor 1, Mei 2019
- Ghaffarian H, Saiedi M: "Synthesis of ZnO Nanoparticles by Spray Pyrolysis Method". *Iran J Chem Chem Eng* (2011), 30 (no. 1):1–6.
- G. Miftahurrahman, Setiarahayu, H. and Nandiyanto, A. B. D. (2019). An Economic Evaluation on Scalling-up Production of Nano Gold from Laboratory to Industrial Scale. *Indonesian Journal of Computing, Engineering and Design* 1(1) (2019) 29-36.
- K. R. Raghupathi, R. T. Koodali, A. C. Manna, Size-dependent bacterial growth inhibition and mechanism of antibacterial activity of zinc oxide nanoparticles, *Langmuir* 27 (2011) 4020–4028.
- L. Zhang, Y. Jiang, Y. Ding, M. Povey, D. York, Investigation into the antibacterial behavior of suspensions of ZnO nanoparticles (ZnO nanofluids), *J. Nanopart. Res.* 9 (2006) 479–489.
- M. Liu, C. Chen, J. Hu, X. Wu, X. Wang, Synthesis of magnetite/graphene oxide composite and application for cobalt(II)removal, *J. Phys. Chem. C* 115 (51) (2011) 25234–25240.
- M. R. Vaezi, S. K. Sadrnezhaad, Nanopowder synthesis of zinc oxide via solo chemical processing, *Mater. Des.* 28 (2007) 515–519.
- Nandiyanto, A. B. D. (2018). Cost analysis and economic evaluation for the fabrication of activated carbon and silica particles from rice straw waste. *Journal of Engineering Science and Technology*, 13(6), 1523-1539.

-
- Pan A, Yu R, Xie S, Zhang Z, Jin C, Zou B: ZnO flowers made up of thin nanosheets and their optical properties. *J Cryst Growth* (2005), 282(1–2):165–172.
- R. Al-Gaashani, S. Radiman, A.R. Daud, N. Tabet, Y. Al-Douri, XPS and optical studies of different morphologies of ZnO nanostructures prepared by microwave methods, *Ceram. Int.* 39 (2013) 2283–2292.
- Wu J-J, Liu S-C: Catalyst-Free Growth and Characterization of ZnO Nanorods. *J Phys Chem B* (2002), 106(37):9546–9551.
- Yan C, Chen Z, Zhao X: Enhanced electroluminescence of ZnO nanocrystalline annealing from mesoporous precursors. *Solid State Commun* (2006), 140(1):18–22.
- Yusan S., Bampaiti A., Aytas S., Erenturk S. and Aslani M. A.A. (2015). Synthesis and structural properties of ZnO and diatomite-supported ZnO nanostructures. *Ceramics International* 42 (2016) 2158–2163
- Z. Ling, C. Leach, R. Freer, Hetero junction gas sensors for environmental NO₂ and CO₂ monitoring, *J. Eur. Ceram. Soc.* 21 (2001) 1977–1980.