

Developing Return Board as an Aid for Forehand Topspin in Table Tennis

Teguh Santosa^{1✉}, Hari Setiono², Sulaiman²

¹ Universitas Negeri Surakarta, Indonesia

² Postgraduate Universitas Negeri Semarang, Indonesia

Article Info

Article History:

Received 12 January
2017

Accepted 20 March 2017

Published 01 June 2017

Keywords:

*return board; top spin; table
tennis.*

Abstract

This study is aimed at developing a return board aid, and assisting athletes and coaches to improve the ability in using forehand topspin in table tennis. A Borg and Gall's research and developmental method is used consisting the following steps: identification of potentials and problems, data collection, developing a preliminary product, expert judgement and revision, small-scale field testing and revision, large-scale field testing, large-scale revision, product application field testing, product revision, and mass production. Ten athletes were involved in the small scale field testing and forty-two athletes were involved in the large-scale field testing. Product validation was conducted by six experts, including 3 practitioners and 3 lecturers. The data were collected by using interviews, observation, and test of product effectiveness, and analysed by using a mini tab 16. The findings show that the return board as a medium aid can be used to improve the ability of the athletes in applying forehand topspin. The product was found to be 53% effective for beginners and 32% effective for advanced athletes. The return board product can be used as a means for practice for junior, beginner, and senior athletes. The product can also be used to motivate athletes in their practice by assessing their ability in forehand topspin stroke.

© 2017 Universitas Negeri Semarang

✉Correspondence:

Jalan Ir. Sutami No. 36A, Jebres, Kota Surakarta, Jawa Tengah 57126

E-mail: teguhsantosa.gelora@yahoo.com

p-ISSN 2085-4943

e-ISSN 2502-4469

INTRODUCTION

Sport is a physical activity needed by every human being. The current development of sport is not related with age, gender, race, ethnicity and religion. The achievement sport can be optimally accomplished is the the training is provided with regular, structured, and planned program and supported with various branches of science and technology. Each branch of sport requires physical training and technology to attain the maximum achievement. Physical training supported with technology for every branch of sport is fundamental, in addition to improving techniques, tactics and mental aspects. Among the factors that enhance the development of sport achievement is the improvement of the quality of sport technology used for sport training and education. Therefore, a scientific approach should be used to improve the sport achievement.

Table tennis is played by using technical, physical and psychological principles. In terms of technical principles, athletes should master various techniques including techniques for holding the bat, striking the ball, and moving legs. The physical principle means that table tennis game requires good physical condition like speed , power, agility, endurance , flexibility, balance, accuracy, and fitness to maintain their game. The psychological principle means that table tennis game requires psychological elements such as intelligence, emotion, motivation, perception, fun, joy, enthusiasm, and sportivity.

The table tennis achievement cannot be attained speculatively, but should be through intensive practice with good practice programs and supported with effective technology. The practice should be specially designed to develop important components of table tennis. The achievement of table tennis could be enhanced through effective practice technology so that the practice will improve the physical quality, table tennis techniques (*service, back hand, fore hand*) and tactics, so it is important to develop the effective practice technology.

Nowadays, the science and technology is advancing very quickly. This is indicated by many of new innovation in various disciplines. Sport is an applied science affected by the technology to support its activities. The technology is used by the coaches and athletes to optimally facilitate the process of practice. Through the development of accurate practice technology, it is expected that the quality of the athletes (physical aspects, techniques, tactics and mental aspects) can be improved and maximum achievement can be made.

There are various factors that influence table tennis achievement including techniques, facilities, technology, funding, competition and development. Based on the data in Surakarta Branch of Indonesian Table Tennis Association from 2010 to 2015, it is found that some factors affect the table tennis achievement in Surakarta include lack of development of practice model and lack of application of technological aids to improve the ability of the athletes in table tennis techniques.

The forehand top spin is a basic technique for athletes and has become the focus of the coaches of the table tennis clubs in Surakarta. Attempts have been made to improve the ability to use this technique by using various modified practice and equipments. Preliminary observation in Dwi Bengawan and Mitra Medika Club in Surakarta shows that (1) there is lack of technology application in table tennis, (2) athletes have low mastery of advanced techniques in table tennis, and (3) there is limited number of coaches. The researcher focuses on the improvement of advanced techniques, i.e. to use forehand topspin stroke with a aid with the technology application in table tennis.

Among the techniques in table tennis, forehand topspin is one dominant technique as suggested by Djokic (2010 : 131) that “forehand top spin table tennis represents the most widely used offensive stroke about 34 % of all strokes and about 60 % of all forehand strokes”. This indicates that the effect of the forehand topspin

contributes highly to the success in the game, so this technique must be mastered by athletes.

This study addresses how to develop an aid to improve the athletes' ability to perform forehand topspin stroke in table tennis.

Table tennis

Table tennis emerged around 1890s as an indoor game and became popular around the world and on 12 December 1926 International Table Tennis Federation (ITTF) was established (Pięta and Pięta, 2011: 67). In Indonesia, PTMSI (Persatuan Tenis Table Seluruh Indonesia - Indonesian Table Tennis Association) was also established and became a member of ITTF in 1961. In the table tennis, two players (in single game) or two teams of two players (in double game) perform the game in a number of sets and compete to obtain scores, using a wooden bat covered with rubber to strike a 40 mm diameter ball made of celluloid passing over the net with the height of 15.25 cm, to arrive at the opponent's table field. On 1 October 2000, the size of the ball was changed from a diameter of 38 mm to 40 mm with the weight of 2.7 gram and is made of celluloid material. The table is 2.74 m long, 1.525 m wide and 76 cm high. ITTF (International Table Tennis Federation) announced the change the ball size from 38 mm to 40 mm (Kondrič, et al., 2006: 26).

Table tennis or known as "pingpong" is a unique and creative sport branch. It is defined as a game by using a table as the field with a net dividing the table into two and a celluloid ball. The game is played by using a bat to strike the ball. As said by Bufton, et al. (2014: 6) the table tennis game is played by using a table, a bat and a ball. In the game, according to Apatini (2016: 1) the players hit the small ball forth and back on the table. They use a wooden paddle or bat to hit the ball passing over the net in the middle of the table. The score is given when the player who receives the ball cannot return the ball, or when the ball falls over outside the table. The basic idea of the game is to present the first ball by reflecting it on the table area of his/her own and the ball must pass over the net and fall into the

table area of the opponent and later return the ball after reflecting it from the table.

Based on the above description, it can be concluded that table tennis is a game with a table, bat and net as a means of reflecting the ball. The player serves the ball passing over the net to the other side of the table, and return the ball to the opponent's area after reflection from his/her own table area.

Forehand Top Spin as a Dominant Technique

The game begins with serving the ball over the net to the opponent's area, then the opponent returns the ball. Gross and Schlager (2011: 17) point out that the service is an important stroke in table tennis. Therefore, to play the table tennis, it is important to practice service movement and return the ball to the target area. The movement skill to return the ball in table tennis should be mastered by the player. This skill can be conducted by using forehand and backhand stroke with an offensive stroke to produce topspin ball and a defensive stroke to produce backspin ball.

According to Geske and Mueller (2010: 13), forehand is a stroke performed on the right side of the player, for a left-handed player the forehand is performed on the left side of the player. The forehand is a type of table tennis stroke having important role in winning the game. The skill in using forehand and backhand stroke includes the use of such techniques as drive, push, block, chop and service. There are five types of forehand and backhand stroke, i.e. (1) drive, (2) push, (3) block, (4) chop, and (4) service

The forehand stroke is important for three reasons:

1. A player needs a forehand stroke to attack from forehand side.
2. The *forehand* can be the main stroke to attack.
3. The forehand is mainly used for smash.

With the topspin stroke, the ball is stricken with strong spin or speed and the ball rotation will pull it down to the table.

The forehand top spin stroke is a technique with the ball rotating clockwise. The

following describes the movement of the spin ball in the table tennis:

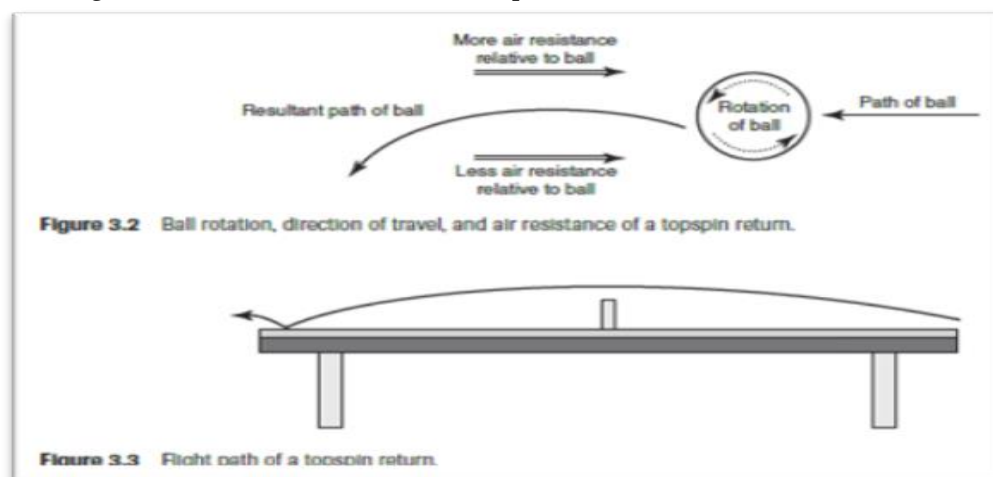

Figure 1. Forehand top spin position ball (Larry Hoghes, 2007).

The *spin* stroke is dominant in the attack illustrates the dominant techniques used by as compared to other types of stroke. Tabel 1. world top players.

Tabel 1. Dominant stroke techniques in table tennis

Variable		Statistical significance		
		N=	Percentage %	Chi Square
Type of offensive stroke	Spin	997	56.648	448.419**
	Smash	454	25.795	
	Counter	309	17.557	

Table 1. shows that the forehand top spin is a significantly used stroke by 56.648 %, as compared with smash by 25.795 %, and counter by 17.557 %.

According to Djokic (2010:131), a Serbian table tennis expert suggests that “forehand top spin in table tennis represents most widely used offensive stroke about 34 % of all strokes and about 60 % of all forehand strokes”. Additionally, based on research journals on the analysis of table tennis techniques, it is found that the forehand top spin is dominantly used as an offensive stroke in table tennis.

Definition of Achievement Sport

Sport is a form of activity to improve physical fitness. It does not only involve a musculoskeletal system, but also other system such as cardiovascular, respiration, excretion, neural and other system. It is important to maintain people’s health and cure sick body. It is also a physical activity to strengthen the body muscular system. This activity is later developed into an enjoyable and fun activity and to develop achievement in sport competition. Effective and efficient acquisition is the main determining factor in the athletes’ achievement in sport. The achievement sport is determined by biological, psychological, sociocultural and environmental factors (Sterdt, Liersch, and Walter: 2013: 1).

Physical activities are defined as every body movement as a result of skeleton muscular activities to produce energy. People perform physical activity depending on their life style and other factors. The physical activity consists of any activity during working, sleeping, and in leisure time. Planned, structured, and repeated activities are included as sport physical activities. By conducting regular exercise, people can prevent themselves from having heart diseases, diabetes, and cancer (Wen, et al., 2011: 1252).

Physical activities are also physical work involving the body locomotor system to carry out daily life activities. A physical activity which is systematically performed with specific objectives and regulations such as time allocation, targeted pulse, and number of repeated movements is called practice. Sport is defined as practice with recreative elements. According to Hargie, et al. (2015: 24), sport is a form of physical activity through organized events or participation, aimed at expressing or improving physical and mental fitness to obtain good health, and forming social relation or attaining some achievement in a competition in all levels.

Table Tennis as Achievement Sport

When the table tennis represents the standard for international achievement sport, it also becomes the standard for national achievement sport for the last 30 years. The table tennis competition was conducted in London in 1926, mainly participated by 7 countries and then by 34 countries. The first international tournament was held in Januari 1926 in Berlin, and the first world table tennis championship was held in December 1926 in London (Chiu, 2012: 2).

In 1930 a UK player was highly seeded, with Fred Derry winning the single player in the Wimbledon championship in 1928-1929. The success by East European players has made Viktor Barna and Richard Bergmann to become legendary players. Barna was renowned as the king of table tennis for 16 years for a single and double player. After the World War II, the table tennis attracted some sympathy and charm

among half of Eropa, Hungaria and Chekoslovakia produced world class players and introduced more advanced techniques in the table tennis game.

Definition of Athletes

In day-to-day communication, we often hear the term 'athletes' to refer to people performing in sport activities. Based on field observation, people are called as athletes when they participate in a competition or championship that involves dexterity power and speed in sport. Additionally, they also must be skillfull in one branch of sport and has excellent achievement in this sport. according to Araujo and Scharhag (2016: 4), the term 'athletes' derives from the Greek word "athlos" which means achievement, so it is related with performing something very good. According to Gundarya (2013: 1) the word 'athletes' comes from the Greek word "athlos" which means "contest" and refers to a person who practices and praticipates in sport competition. In this way, it can be concluded that athletes are sport people, especially those taking part in the competition or championship.

In this study, athletes are defined as people who dedicate themselves in table tennis and have some achievement in this sport branch.

Categories of Table Tennis Athletes

There are various factors that help the athletes achieve their maximum performance. The athletes' category is one factor that influences their achievement. There are a number of games in table tennis tournaments including men's and wome's single, mixed students' group, students' men's and wome's single, veteran men's single, cadet men's and women's single, junior men's and women's single, and executive category. According to Gross and Schlager (2011: 124) the demand for single players is different from that of double players. The players should strike the ball consecutively, so the movement and space are different. In terms of tactics, the service in double player game is different because the player should serve diagonally. The partner

player in double game should agree to the tactics and psychologically and mentally support to each other because they play as a team.

Definition of Practice

Practice is a process that athletes should go through to achieve high achievement. One way to improve their sport achievement is by practice. About the process and length of practice, Bumpa and Carrera (2015: 1) state that "in sport, practice is a process repeatedly performed". According to Bumpa, et al. (2013: 10), practice is a complex activity regulated by methodological principles and guidelines to help athletes achieve the size and limit of the biggest muscles. Practice is a systematic process, performed repeatedly, day by day adding the load of the practice or work.

Through physical practice, people can improve most of their physiological system and can adapt to the demand of the function higher than what they can do. Physical practice is a physical activity performed systematically, repeatedly in a long term with gradually and individually adding the load to establish physiological and psychological condition, to perform the job properly.

The object of practice process in table tennis is human being to improve their ability, skill, and performance with the guidance from coaches. The objective of the practice is to improve the athletes' achievement in acquiring and applying the theories into practice. Sukadiyanto (2010: 10) states that practice is generally meant to: (1) improve the basic physical quality in a general and comprehensive manner, (2) develop and improve the specific physical potentials, (3) add and improve techniques, (4) develop and improve strategies, tactics, and playing patterns, (5) improve the psychological quality and ability of the athletes when playing in competition.

The practice program for athletes should be designed accurately and implemented properly. The practice principles in table tennis are not different from other sport. According to Djoko Pekik Irianto (2009: 7-13), the planning

and implementation of practice program should consider the following principles:

Active participation.

The achievement is a combination of athletes' efforts and coaches' hard work, so the athletes and coaches are responsible for the implementation of practice programs to attain high achievement.

Multilateral development.

High achievement should be prepared through establishing basic multilateral development. This basic stage of multilateral development is given at the beginning of the program before entering specialization stage, usually for kids between the age of 6-15.

Individual.

Every athlete has different and unique potentials and character, and every practice results in different responses. Therefore, different athletes require different programs according to their abilities.

Overload.

To improve athletes' ability, overload practice is required, by giving the load to the critical point of the athletes, but for children, the physical practice should be given according to their capacity.

Specification.

As table tennis coaches and athletes, they should fully understand the characteristics of table tennis. The implementation of principles of practice specification should consider the following issues: (1) specification of energy needed by the athletes, (2) specification of practice forms and models for table tennis, (3) specification of movements and muscle groups performed by the athletes, and (4) length of practice periods.

Reversible

It is defined as the decrease of the athletes' ability as a result of irregularity in running the practice.

Variation.

Good practice programs should be variedly organized to avoid boredom, tense, and restlessness as psychological fatigue. One way to make the more varied practice is by changing the forms, location, facilities and equipments, or sparring partners. Even though those elements are changed, the main objectives should not be changed.

Based on the above description, it can be concluded that practice is a systematic, repeated, continuous physical activity, with the addition of practice load (over load principle) in a periodic stages and implemented based on its intensity, patterns, and methods to improve the athletes' achievement .

METHODS

This study adopted a research and development method, aimed at developing a certain product, and testing the effectiveness of the developed product (Sugiyono, 2009: 407). Borg and Gall (2003: 775) suggest that the research and development strategy is used to develop and validate educational products. In this study, a return board aid is developed to improve the ability of top spin stroke in table tennis. The development of the model of the return board aid in Surakarta is to improve the ability of forehand top spin stroke and to improve the athletes' achievement.

Borg and Gall (2003) state that there are two objectives of research and development: developing a product and validating the effectiveness of the product. Three steps were used in this study: (1) pre-development stage, (2) product development stage, (3) product validation stage.

In the pre-development stage, a preliminary study was carried out by conducting a survey by asking questions to the coaches about the athletes' ability in table tennis strokes, collecting documents about difficulties by coaches to develop the athletes' ability in performing table tennis strokes, collecting documents about practice models by athletes to pursue maximum achievement, making

literature review on the athletes' competence in forehand top spin and on theories about table tennis.

In the development stage, a preliminary product of the return board aid model to improve the athletes' ability to perform forehand top spin stroke was planned and developed. This stage involved the following steps: (1) analyzing and defining the ability to perform forehand top spin, (2) analyzing the table position and sign of target location, (3) analyzing the distance and tilt of the return board, (4) analyzing the objectives and characteristics of the instrument of the ability to perform the forehand top spin, (5) analyzing the instructions for the tests and scores of the instruments on the accuracy of the athletes' ability to perform forehand and backhand drive, (6) preparing the construction of a preliminary product design of the instruments on the accuracy of the athletes' ability to perform forehand and backhand drive.

In the product validation stage, the content and empiric validation was conducted on the instruments of the accuracy of the athletes' ability to perform forehand top spin drive. The validation was intended to find out the feasibility of the instruments to measure the athletes' ability to perform top spin stroke.

The content validation was conducted by using Delphi techniques (Dunn, 1994: 366) by five experts, i.e three experts in table tennis coaching, and two experts in sport education. The experts' assessment was intended to improve the preliminary product design, especially in terms of the accuracy of the table signs, the size of the target, and the target scores, the accuracy of the rally, the accuracy of the test instructions, the accuracy of the scoring, and to obtain the legitimization from related academic fields. The preliminary product was finalized when the revision of the the accuracy of table signs, target size and scores, the accuracy of the rally, the accuracy of the the test instructions, and the accuracy of the scoring were made.

The evaluation was made after obtaining inputs from experts, consisting of table tennis coaches and lecturers. Then, the preliminary product was revised to improve the product

before the product went through the large scale product testing. Empiric validation was conducted through field testing to obtain responses and to revise the product, so finally to obtain the valid forehand top spin aid. The small scale and large scale testing was conducted.

In the preliminary study, the data were collected by using a survey by distributing questionnaires to table tennis experts (coaches and lecturers). Additionally, observation was also used to obtain the information from experts and information about the product.

The data were then analyzed qualitatively and quantitatively. To answer the objectives of the study to find out the effectiveness of the product, the data were processed and analyzed by using (1) descriptive analysis, and (2) inferential analysis to find out the effectiveness of the product, assisted with mini tab 16.

RESULTS AND DISCUSSION

This study was conducted in table tennis clubs in Surakarta City, consisting of Mitra Medika, Dwi Bengawan and UTP tennis clubs. In this study, the researcher involved 3 coaches from each club as practitioners and 3 lecturers as table tennis experts. Ten 10 athletes were involved in the small scale field testing and 40 athletes were involved in the large scale field testing. The athletes performed some practice by using return board aid to improve the athletes' ability to use forehand topspin stroke techniques. Before performing the practice, the athletes' ability to perform forehand topspin stroke by striking the ball to the aid for 30 seconds was pretested and the number of correct strokes was counted. Then, the athletes were trained for two months to use the aid as an experiment. After that, they were tested again to find out whether their ability to perform the forehand top spin stroke was improved or not (post test). This was conducted to examine the effectiveness of the return board aid to the improvement of the

athletes' ability to perform the forehand top spin stroke.

To find out the validity of the instruments, the try-out of the product effectiveness was conducted by using observation, interviews, documents and discussion by involving experts and athletes. Descriptive notes were used to record any events during the field try out by describing in detail all situations and events during the study.

In the observation, interviews, and document collection, the researcher involved expert judgment from lecturers and practitioners, and in the discussion experts in testing were involved to provide some inputs and to validate the data through triangulation. In this process, experts evaluated and gave inputs to the data collected by the researcher in the field study.

Focus Group Discussion (FGD) was held after the field testing of the product model of *return board aid*. In this FGD, the researcher obtained as much suggestion as possible from practitioners and lecturers. FGD was not only meant to obtain comments from experts but also as a means of obtaining the data validity and to maintain the study reliability. All experts were involved in giving their opinions about what happened in the field during the preliminary product field testing, hence giving opportunities to the researcher to draw a preliminary summary and revision to the product for the following stage.

During the field testing, the researcher documented the data in pictures and videos. The pictures and videos were used to assist the experts to assess and comment on the product being tested.

The Product of Return Board Aid for Forehand Top Spin

To fully understand the developed product, the return board aid is divided into 3 (three) sections:

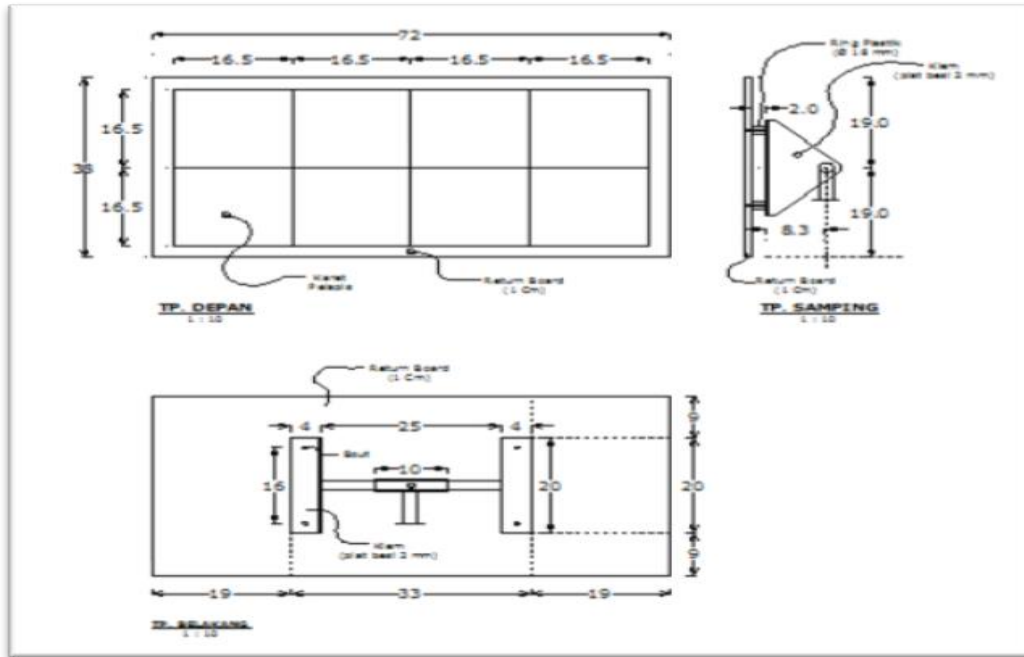

Figure 2. Top section

The top section consists of iron plat, and iron vault. The iron plat is used as the location to attach the board, and the iron vault is used to support the board.

The middle section of the *return board* aid consists of a 2 cm diameter round iron (vault), and 1.6mm thick. This section is used to erect the body return board.

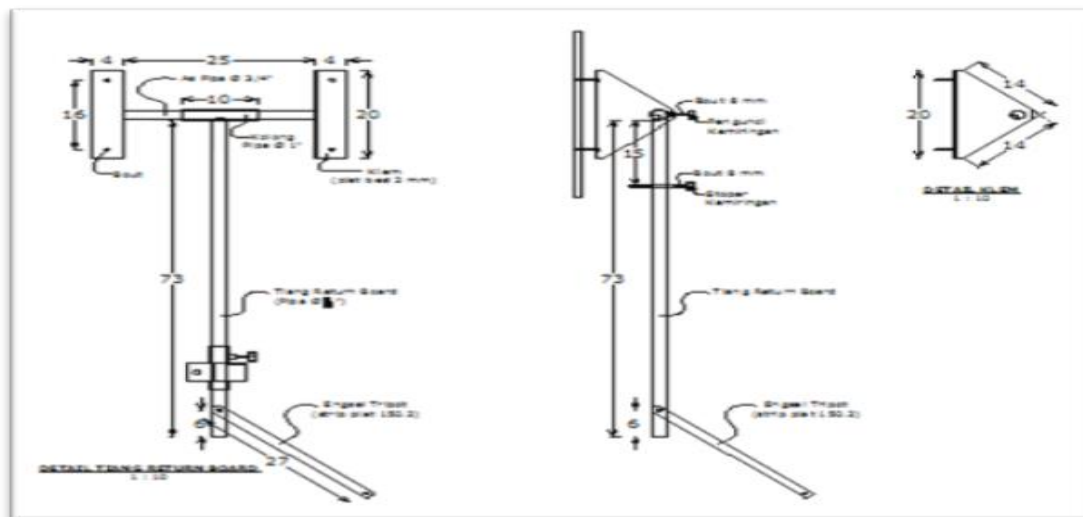

Figure 3. Iron middle section (body):

The bottom section of the product consists of three supporting iron pillars in three feet forms. The iron is 60 cm long

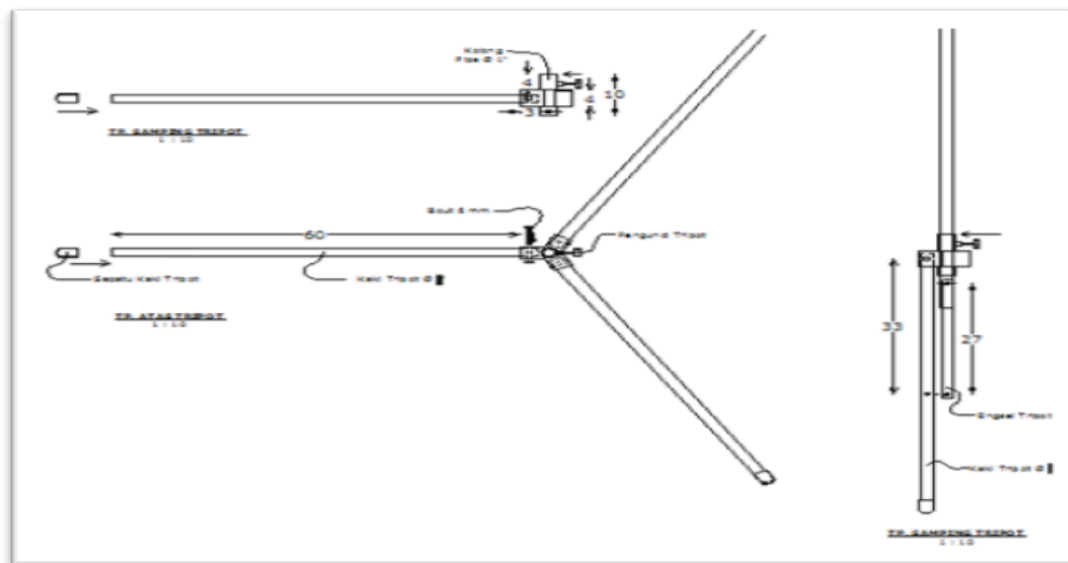

Figure 4. Bottom section (feet)

The Results of the Field Testing of the Return Board Product

The testing of the use of the product was conducted to compare between the pretest and the posttest of the sample (experimental group and control group). There were two experimental groups: beginner athletes and advanced athletes, each consisting of 14 athletes. The results of the pretest and posttest showed that (1) the product of return board aid can be used to improve the forehand topspin stroke. The beginners had 53% effectiveness and the advanced group had 32% effectiveness; (2) The product can be used as practice facilities for the

junior, beginner, and senior table tennis athletes; (3) the product can be used as a means to motivate the athletes to practice by measuring their ability to perform their forehand topspin stroke.

Based on the pretest and posttest scores, a t-test was calculated for each group. Before the t-test was done, normality tests and homogeneity tests were conducted.

1. Normality tests

The normality test was conducted by using Anderson-Darling tests at the significance level of 99% (at the margin error of 1%). All the computation was made by using Minitab 16.

Table 2. Summary of the Normality tests

No.	Group	Test	Value AD	p-value	Note
1	Control	Pretest	0.960	0.011	Normal
		Posttest	0.682	0.058	Normal
2	Beginner	Pretest	0.285	0.572	Normal
		Posttest	0.302	0.530	Normal
3	Advanced	Pretest	0.297	0.540	Normal
		Posttest	0.595	0.098	Normal

Based this normality tests, it can be concluded that all groups were normally distributed and met the requirement.

2. Homogeneity tests

The homogeneity test was done by using Levene test at the significance level of 99% (the margin error of 1%). All the computation was made by using Minitab 16.

Table 3. Homogeneity Test for Testing Effectiveness

No	Group	Levene's Test Value	p-value	Note
1	Control	1.11	0.301	Homogeneous
2	Beginner	0.68	0.416	Homogeneous
3	Advanced	0.11	0.739	Homogeneous

Based on the homogeneity test, it can be concluded that that all groups were homogeneous and and met the requirement.

3. T-test

The pretest scores were compared with those of posttest for each group by using a paired t-test. All the computation was made by using Minitab 16.

Table 4. Results of t-test for control group

Paired T for PRE-C - POS-C					
	N	Mean	St.Dev	SE	Mean
PRE-C	14	19.286	1.267	0.339	
POS-C	14	21.000	1.710	0.457	
Difference	14	-1.714	2.268	0.606	

95% CI for mean difference: (-3.024, -0.405)

T-Test of mean difference = 0 (vs not = 0): T-Value = -2.83 P-Value = 0.014

Because the p-value was (0.014) > 0.01, it can be concluded that there was no significant difference between the pretest and posttest scores for the control group. Although the mean of the posttest scores were higher than the mean of the

pretest scores, the difference was not statistically significant.

1) For Beginner Athlete Group

Table 5. Results of t-test Beginner Athlete Group

Paired T for PRE-P - POS-P					
	N	Mean	St.Dev	SE	Mean
PRE-P	14	17.000	2.828	0.756	
POS-P	14	25.214	3.286	0.878	
Difference	14	-8.21	4.26	1.14	

95% CI for mean difference: (-10.68, -5.75)

T-Test of mean difference = 0 (vs not = 0): T-Value = -7.21 P-Value = 0.000

Because the p-value was (0.000) < 0.01, it can be concluded that there was significant difference between the pretest and posttest scores for the beginner group. The mean of the the posttest scores were higher than the mean of the pretest scores. There was a difference of 8.7, and it showed that the product had the effectiveness of 53% for this group.

2) For Advanced Athlete Group

Table 6. Results of t-test Advanced Athlete Group

Paired T for PRE-L - POS-L				
	N	Mean	St.Dev	SE
PRE-L	14	27.000	3.721	0.994
POS-L	14	35.714	3.730	0.997
Difference	14	-8.714	2.585	0.691

95% CI for mean difference: (-10.207, -7.222)

T-Test of mean difference = 0 (vs not = 0): T-Value = -12.61 P-Value = 0.000

Because the p-value was (0.000) < 0.01, it can be concluded that there was significant difference between the pretest and posttest scores. The mean of the the posttest scores were higher than the mean of the pretest scores. There was a difference of 8.7, or an increase of 32%. Therefore, the product could improve the athletes' ability to perform the forehand spin stroke with the effectiveness of 32%.

Based on the steps in this research and development study, the final product of return board aid was developed for senior table tennis athletes to improve the forehand top spin stroke. The success of the product was indicated from the analysis of the field testing (observation, interviews, discussion), and the assessment from experts, including lecturers and coaches.

Based on the field testing of the use for the product, the final model of the product of the return board forehand topspin aid was found to improve the senior athletes' ability to perform the forehand top spin stroke. The product can be used to facilitate the athletes to practice, and to help the coaches use the product as a reflecting board during the practice.

The indicators of the success of the product are described below:

1. The assessment scores to the product during the preliminary stage, the small scale and large scale field testing indicate that the scores from all experts ranges in the interval

of $(\mu+1,0\sigma) \leq X$, and this is classified as high caategory.

2. Based on the questionnaires, the subjects generally have positive assessment towards the return board aid.
3. The effectiveness test shows that the athletes' ability to perform the forehand top spin stroke significantly improves by 32%. The test was conducted for 30 seconds, with the return board was located in its ideal position of 40/70⁰, i.e. the distance of board-table is 40 cm, and the tilt is 70 degrees.

Product Strengths and Weaknesses

The product has the following strengths:

1. Originality: the product is the researcher's work with typical features from needs analysis in the field.
2. Inovative Excellence: the product is excellent in quality, innovation, and materials, and easy to operate and maintain.
3. Additional Outstanding Features: the product can be adjusted in terms of hight, tilt, and distance as needed by the athletes/ coaches during the practice activities.
4. Economical: the product is affordable and effective to support the development of table tennis.
5. Safety and Security: the product is highly safe, secure, and comfortable for athletes.
6. Complete Data Support: the product is accompanied with a manual for use (guide book and manual CD) and description about the results of field testing.

The product has the following weaknesses:

1. Product research and development: the product should be developed in much longer time so that the product effectiveness can be strongly established.
2. Data triangulation process: more experts, including lecturers and table tennis practiitioner/ coaches should be involved.

Limitation of the Study

This study was maximally and genuinely designed and implemented to develop a beneficial product for sport development. However, the researcher is aware that this study

has some limitation and weaknesses. Some limitation is described below:

1. The product model of the return board forehand top spin aid did not adopt automatic technology, but was only manually operated.
2. The researcher did not fully adopt all Borg and Gall's steps, but modified them because of economical reasons and time constraints.
3. The study developed the product only to improve the athletes' ability to perform the forehand top spin stroke.

CONCLUSION

After undergoing the development process following Borg and Gall' method, the model of return board aid to improve the performance of forehand top spin in table tennis, abbreviated as RBFT (returnboard for forehand topspin) was finalized. Based on the discussion in this study, it can be concluded that the product model can be used to improve the athletes' ability to perform forehand top spin stroke and the effectiveness for for beginners is 53% and for advanced group is 32%. It can be used as equipment for practice for junior, cadet and senior athletes. It can also be used to motivate the athletes in practice activities by measuring their ability to perform forehand top spin stroke.

This study implies that RBFT provides some hope for coaches and athletes to improve their movements and ability to perform forehand top spin stroke. It is also an alternative product that can solve some problems in the development of table tennis in schools. For scientists, researchers and practitioners, they know that standard equipment with high technology like robotic equipment is expensive and difficult to obtain, so RBFT could be used as a response for the development of facilities as needed by the society. Scientists and researchers are encouraged to conduct further studies about sport equipments and practitioners should help produce the equipments and distribute them.

It is suggested that Surakarta Table Tennis Association, Table Tennis Clubs, and schools are encouraged to use the product model of

RBFT aid to facilitate their athletes to practice both for beginners and seniors. Coaches should use it to train their athletes to perform the forehand top spin stroke and socialize it to clubs. Office of Education and Sport should multiply the products and distribute them to students sport clubs in schools. Finally, sport industries can make mass production of the product to encourage the sport equipment industry.

ACKNOWLEDGEMENT

I would like to express my most heartfelt and sincere gratitude to Prof. Dr. Soegiyanto, KS. for his encouragement, patience and invaluable supervision and guidance. His kind, generous, and thoughtful assistance meant a great deal to me in completing this article.

REFERENCES

- Apatini, J. 2016. Progressive Weighted Aerobic Ping Pong Exercise Racquet. United States Patent Application Publication. Pub. No.: US 2016/0243416 A1, p: 1-4.
- Araujo, C.G.S., and Scharhag, J. 2016. Athlete: A Working Definition for Medical and Health Sciences Research. *Scand J Med Sci Sports*, 26: 4-7.
- Bompa, T.O., and Buzzichelli, C.A. 2015. *Periodization Training for Sports*. Third Edition. United States of America: Human Kinetics.
- Bompa, T.O., and Carrera, M. 2015. *Conditioning Young Athletes*. United States of America: Human Kinetics.
- Bompa, T.O., Pasquale, M.D., Cornacchia, L.J. 2013. *Serious Strength Training*. Third Edition. United States of America: Human Kinetics.
- Borg & Gall. 2003. *Educational Research*. New York: Allyn and Bacon.
- Buften, A., Campbell, A., Howie, E., Straker, L. 2014. A Comparison of the Upper Limb Movement Kinematics Utilized By Children Playing Virtual and Real Table Tennis. *Human Movement Science*. 38: pp. 84-93.

- Chiu, R.W. 2012. Portable Ping-Pong Set. United States Patent. Patent N0: US 8,182,374 B1, p: 1-20.
- Djokic, Z. 2005. The proceeding of the 9 IITF Science Congress.
- Djoko Pekik Irianto. 2009. Panduan Gizi Lengkap Keluarga dan Olahragawan. Yogyakarta: Andi Offset
- Edwards, William H. 2011. Motor Learning and Control: From Theory to Practice. USA: Wadsworth Cengage Learning.
- Gross, B.U., and Schlager, W. 2011. Table Tennis: Tips from a World Champion. UK: Meyer & Meyer Sport.
- Gundarya, D.N.H. 2013. Home Prestasi. Jakarta Pusat: STIE Try Dharma Widya.
- Hargie, O., Somerville, I., Mitchell, D. 2015. Social Exclusion and Sport in Northern Ireland. Jordanstown: Ulster University.
- Kondrič, M., Mandić, G.F., and Medved, V. 2006. Myoelectric Comparison Of Table Tennis Forehand Stroke Using Different Ball Sizes. Acta Univ. Palacki. Olomuc., Gymn. Vol. 36, no. 4: 25-31.
- Pięta, W., and Pięta, A. 2011. Czech and Polish Table Tennis Players of Jewish Origin in International Competition (1926-1957). Physical Culture and Sport Studies and Research. Volume LIII: 65-75.
- Sterdt, E., Liersch, S., and Walter, U. 2013. Correlates Of Physical Activity Of Children And Adolescents: A Systematic Review Of Reviews. Health Education Journal, 0(0): 1–18.
- Sugiyono. 2011. Metode penelitian pendidikan: pendekatan kuantitatif, kualitatif, dan R&D. Bandung: Alfabeta.
- Sukadiyanto. 2011. Pengantar Teori dan Metodologi Melatih Fisik. Bandung: Lubuk Agung.
- Wen, C.P., Wai, J.P.M., Tsai, M.K., Yang, Y.C., Cheng, T.Y.D., Lee, M.C., Chan, H.T., Tsao, C.K., Tsai, S.P., Wu, X. 2011. Minimum Amount of Physical Activity for Reduced Mortality and Extended Life Expectancy: A Prospective Cohort Study. The Lancet. Vol 378: 1243-1253.
- Yasser, Kamal, M. S., et al. 2010. Analytical study for some offensive skills for advanced level junior players in the ITTF protour Egypt 2008. International Journal of Table Tennis Sciences, No.6.